

Application Examples

Introduction

Optocouplers are used to isolate signals for protection and safety between a safe and a potentially hazardous or electrically noisy environment. The interfacing of the optocoupler between digital or analogue signals need to be designed correctly for proper protection. The following examples help in this area by using DC and AC input phototransistor optocouplers.

Optocouplers in IC Logic Design

To interface with TTL logic circuits, Vishay offers a wide range of 4 pin and 6 pin optocoupler series such as the CNY17x, SFH61xA, TCET110x, or K817P family.

- a) Supply voltage: $V_{CC} = 5\text{ V}$
- b) Operation temperature range: $-20\text{ }^{\circ}\text{C}$ to $+60\text{ }^{\circ}\text{C}$
- c) Service life of application: 10 years

Example 1

Phototransistor wired to emitter resistor.

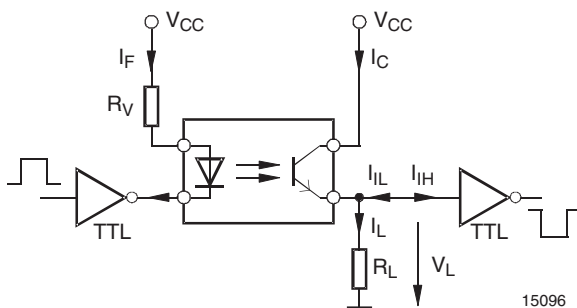

For simplicity, a typical CTR value of 100 % at $I_F = 10\text{ mA}$ is selected. Within the temperature range of $-20\text{ }^{\circ}\text{C}$ to $+60\text{ }^{\circ}\text{C}$ the CTR undergoes change between +12 % and -17 %. The -17 % reduction is critical as applied to functioning of the circuit.

Assuming a 10-year service life period of the interface circuit, allowance needs to be made for additional CTR reduction of approximately 20 % on account of degradation. Making an additional tolerance allowance of approximately -25 % for the CTR will result in a safe minimum value of approximately 50 %.

$$CTR_{\min} = 100\% \times (0.83) \times (0.80) \times (0.75) = 49.8\%$$

For a defined low state at the output of the optocoupler the voltage V_L at R_L must be $V_L \leq 0.8\text{ V}$ and cur-

rent I_{IL} ($I_{IL\max} = 1.6\text{ mA}$) must be capable of flowing through R_L from the TTL input.

Owing to the phototransistor in this case being blocked at the output of the optocoupler and I_{CEO} maximum 200 nA (at approximately $60\text{ }^{\circ}\text{C}$), $I_L - I_{IL}$ setting can proceed practically without any error.

This results in the following maximum value of R_L :

$$R_L < \frac{V_{IL}}{I_{IL}} = \frac{0.8\text{ V}}{1.6\text{ mA}} = 500\Omega$$

A voltage V_L at R_L resistor of $V_{IH} \geq 2\text{ V}$ is necessary in order to attain a safe high state at the output. This needs to be generated by the collector current I_C of the phototransistor.

In the case of the TTL output at the input of the optocoupler the current should remain $I_{OL} \leq 16\text{ mA}$. The CTR value of 50 % results in maximum output current I_C for the optocoupler of 8 mA.

With $I_L = I_C + I_{IH}$ and I_{IH} for standard TTL being maximum 40 μA , $I_L = I_C$ can be assumed without any essential error.

This allows the minimum value to be determined for R_L .

$$R_L > \frac{V_{IH}}{I_L} = \frac{2\text{ V}}{8\text{ mA}} = 250\Omega$$

If for example $R_L = 390\ \Omega$ is selected and 20 % safety is computed to the minimum V_{IH} in respect of the high state ($V_{IH} + V_{IH} \times 20\% = 2.4\text{ V}$), this will then permit

I_C , I_F and the dropping resistor R_V at the input of the optocoupler to be determined,

$$I_C = I_L > \frac{2,4V}{390\Omega} = 6.15 \text{ mA}$$

$$\rightarrow I_F > \frac{6.15 \text{ mA}}{CTR} = 12.3 \text{ mA}$$

With $V_F = 1.2 \text{ V}$, (the forward voltage of the IR diode) and $V_{OL} \leq 0.4 \text{ V}$ for the TTL output follows

$$R_V > \frac{V_{CC} - V_F - V_{OL}}{12.3 \text{ mA}} = 276\Omega, R_V = 270\Omega$$

The TTL interface with the optocoupler is able to transmit signals having a frequency of $> 50 \text{ kHz}$ or a transmission rate of $\geq 100 \text{ kbit/s}$.

In the same way, the optocoupler can interface with other logic circuits, e.g., LSTTL or HCMOS, HCTMOS components. All that needs to be done is to work the corresponding limit values V_{IH} , V_{OH} , I_{IL} , I_{OL} , etc., into the computation for the relevant family.

If use is made of LSTTL or HCTMOS components this will also bring about an essential reduction in current consumption.

Example 2:

Phototransistor wired to collector resistor

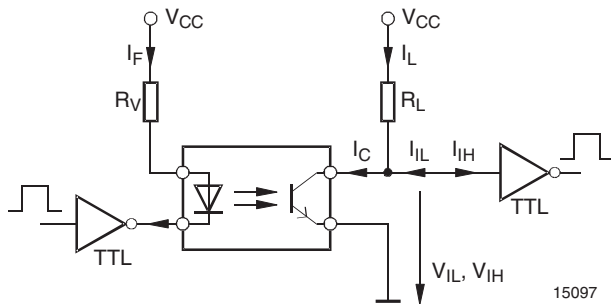

The CTR is determined applying the same calculation – 50% – as that given in example 1. In this example dimensioning of the interface is launched from the high state at the output of the optocoupler.

In the high state a non-operate current of the I_{IH} – of maximum $40 \mu\text{A}$ – may flow in the TTL input. If R_L

selection is too high, the entire non-operate current $= I_{CEO} + I_{IH}$ may produce such a voltage drop through the R_L that the critical V_{IH} voltage (minimum = 2 V), is not attained.

$$R_L < \frac{V_{CC} - V_{IH}}{I_{CEO} + I_{IH}} = \frac{5V - 2V}{40,2\mu A} = 74,6 \text{ k}\Omega$$

or if another + 20% safety is added to the V_{IH} voltage,

$$R_L < \frac{V_{CC} - (V_{IH} + V_{IH} \times 20/100)}{I_{CEO} + I_{IH}} = \frac{5V - 2,4V}{40,2\mu A} = 64,7 \text{ k}\Omega$$

For calculating the smallest usable R_L -value $I_{Cmax} = 8 \text{ mA}$ is assumed as in example 1 and use is made of the low state of the optocoupler output. In this circuit the current I_{IL} of the TTL input flows through the phototransistor in such a way that the following applies: $I_C = I_L + I_{IL}$.

This results in the following:

$$R_L > \frac{V_{CC} - V_{IL}}{I_{Cmax} - I_{IL}} = \frac{5V - 0,8V}{6,4 \text{ mA}} = 656\Omega$$

To select the value for R_L the following should be observed.

Proceeding from the voltage $V_{IL} = 0.8 \text{ V}$ the phototransistor is on the limits of saturation.

Owing to the voltage V_{CE} being relatively unstable in this state, V_{CE} should be selected in such a way that the phototransistor is in full saturation.

From the diagram V_{CEsat} vs. I_C in any given 4 pin or 6 pin phototransistor data sheet, CTR reduced by 50% and for $I_C < 5 \text{ mA}$ follows $V_{CEsat} < 0.5 \text{ V}$.

Vishay Semiconductors

I_{Cmax} is now reduced to approximately 4 mA and for the minimum R_L follows,

$$R_L > \frac{V_{CC} - V_{CEsat}}{4mA - 1.6mA} = \frac{5V - 0,5V}{2,4mA} = 1875\Omega$$

If a suitable value is selected for the resistor R_L it is possible to determine R_V at the input.

Example for $R_L = 5.1 k\Omega$ follows

$$I_L = \frac{V_{CC} - V_{CEsat}}{R_L} = \frac{5,5V}{5.1k\Omega} = 1.08mA$$

$$I_C = I_{IL} + I_L = 2.68 mA$$

$$\text{and with } CTR = 25 \% \quad I_F = I_C / CTR = 10.72 mA$$

$$R_V = \frac{V_{CC} - V_F - V_{OL}}{10.72mA} = 317\Omega, R_V = 330\Omega$$

This interface circuit can be used for transmission rates of up to about 28 kbit/s. The fact that considerably lower transmission rates are possible here compared with the circuit given in example 1 is partly due to the saturation state of the phototransistor and to a large extent to the higher value required for R_L .

Example 3:

Here are other circuit configurations to interface with TTL circuit, specifically the 7400 family.

TTL Active Level Low (7400)

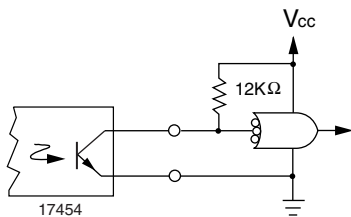

Note: Use smaller pull up resistor for higher speed.

It is more difficult to operate into TTL gates in the active level high configuration. Some possible methods are as follows:

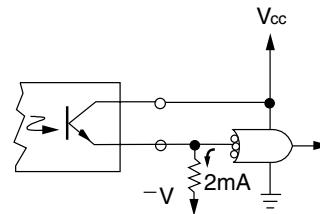

Note: Best method if negative supply is available.

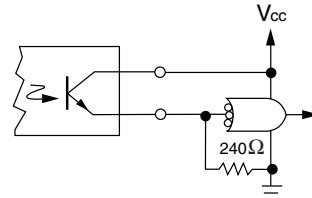

Note: Requires 10 mA from transistor and sacrifices noise margin.

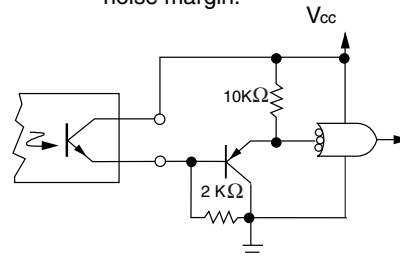

Note: High sensitivity but sacrifices noise margin. Needs extra parts.

17455

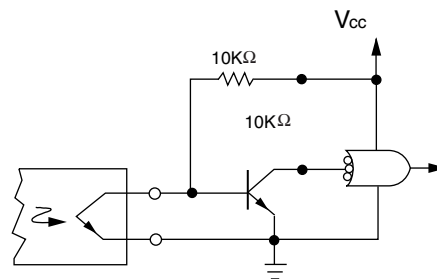

Note: Extra parts cost but high sensitivity.

17456

Obviously, several optocoupler output transistors can be connected to perform logical functions.

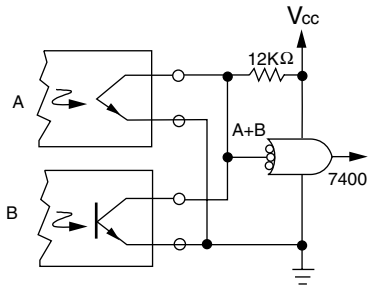

Note: Logical OR connection.

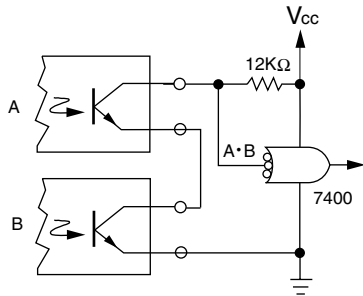

17457

Note: Logical AND connection.

Input Driving Circuits

The input side of the optocoupler has an emitter characteristic as shown.

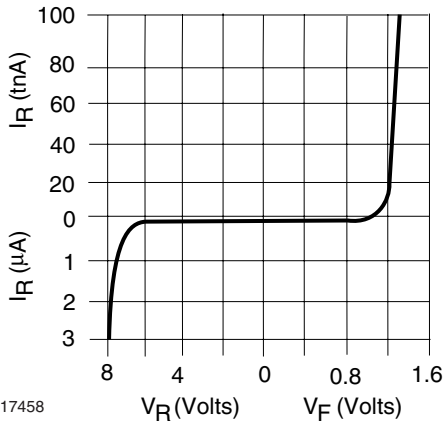

17458

The forward current must be controlled to provide the desired operating condition.

The input can be conveniently driven by integrated circuit logic elements in a number of different ways.

TTL Active Level High (7400 Series)

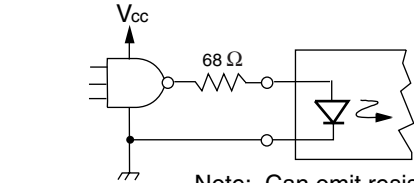

17459

Note: Can omit resistor for about 15 mA into diode.

TTL Active Level Low (7400 Series)

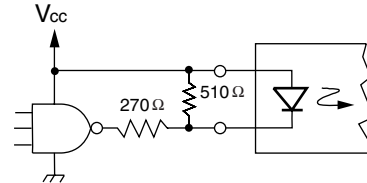

Note: More parts required than above.

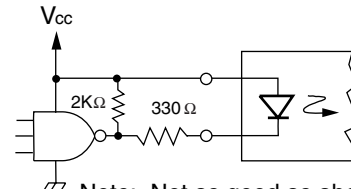

17460

Note: Not as good as above circuit. Not recommended.

There are obviously many other ways to drive the device with logic signals, but a majority can be met with the above circuits. All provide 10 mA into the LED giving 2 mA minimum out of the phototransistor. The 1 V diode knee and its high capacitance (typically 100 pF), provides good noise immunity. The rise time and propagation delay can be reduced by biasing the diode on to perhaps 1 mA forward current, but the noise performance will be increased.

AC Input Compatible Optocoupler

Introduction

With the rapid penetration and diversification of electronic systems, demand for optocouplers is strengthening. Most popular are products featuring compact design, low cost, and high added value. To meet the market needs, Vishay is expanding the optocoupler. This application note focuses on optocouplers compatible with AC input, and covers configuration, principles of operation, and application examples.

Configuration (Internal PIN Connection Diagram)

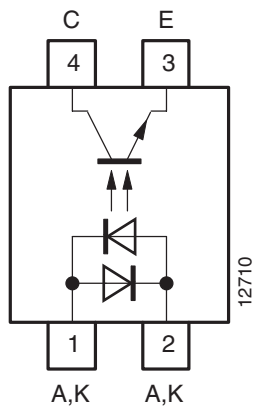

Figure 1. 4-Pin AC Input Optocoupler

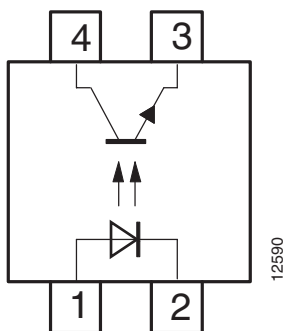

Figure 2. 4-Pin DC Input Optocoupler

Figure 1 shows the internal pin connection of a 4-pin AC input SFH620A-x optocoupler TCET1600, K814P Series, and Figure 2, of a 4-pin DC input optocoupler TCET1100, SFH61xA-x, and K817P Series. The main difference is that the AC input optocouplers incorporates an input circuit with two Emitters connected in reverse parallel. In the DC input optocoupler one Emitter is connected in the input circuit so that the Emitter emits light

to provide a signal when a current flows in one direction (1→2 in Figure 1) (one-direction input type).

However, in the configuration shown in Figure 2, when a current flows in direction 1 to 2, Emitter1 emits light to send a signal, and when it flows from 2 to 1, Emitter 2 emits light to send a signal (bidirectional input type). Namely, even if the voltage level between 1 and 2 varies, and the positive and negative polarities are changed, either of two Emitters emits light to send a signal. This means that the one-direction input optocoupler permits DC input only, while the bidirectional input type permits AC input as well. The next section describes the status of output signals when V_{ac} power is directly input to an AC input compatible optocoupler via a current limit resistor.

Example 1: AC-DC converter

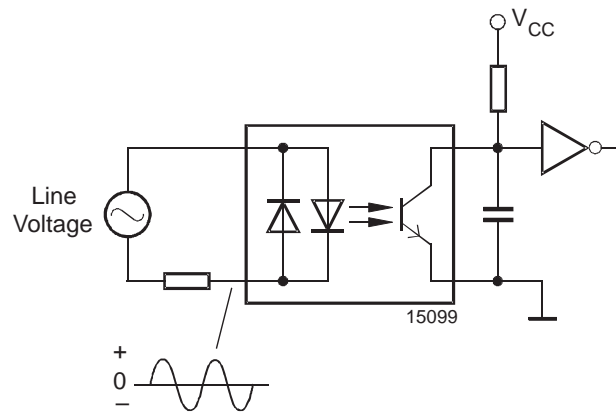

Figure 3. AC input compatible optocoupler (bidirectional input)

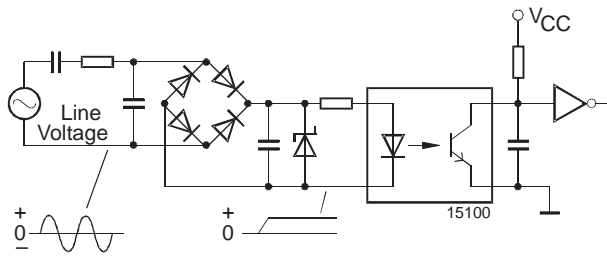

Figure 4. Conventional optocoupler (one-direction input)
(Full-wave rectification by means of diode bridge)

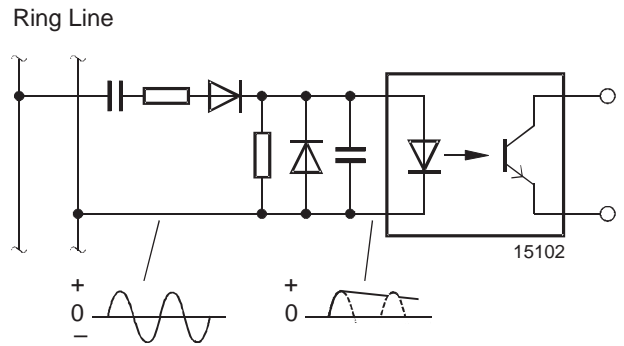

Figure 6. Conventional optocoupler (one-direction input)
(rectified by CR circuit)

Example 2: Detection of a telephone bell signal

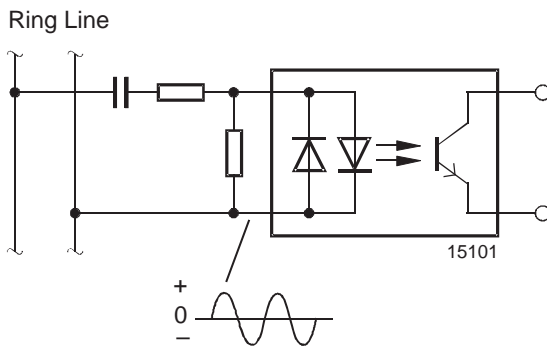

Figure 5. AC input compatible optocoupler (bidirectional input)

Example 3: Sequencer circuit input section

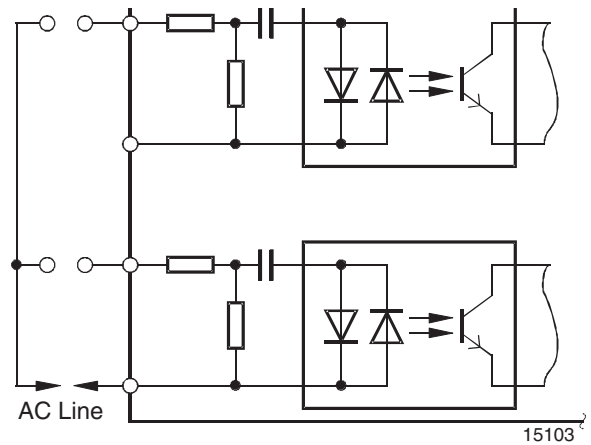

Figure 7. AC input compatible optocoupler (bidirectional input)

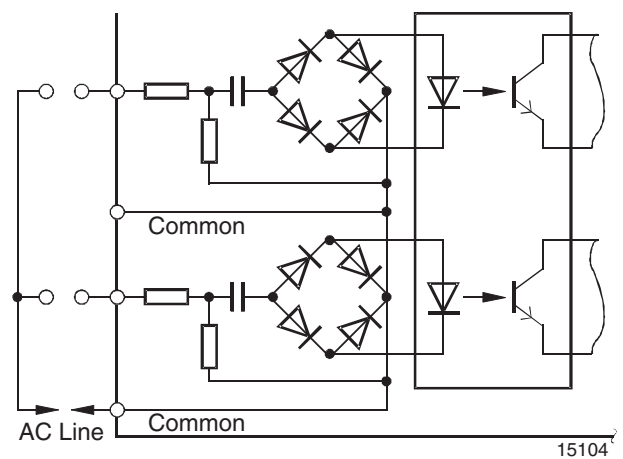
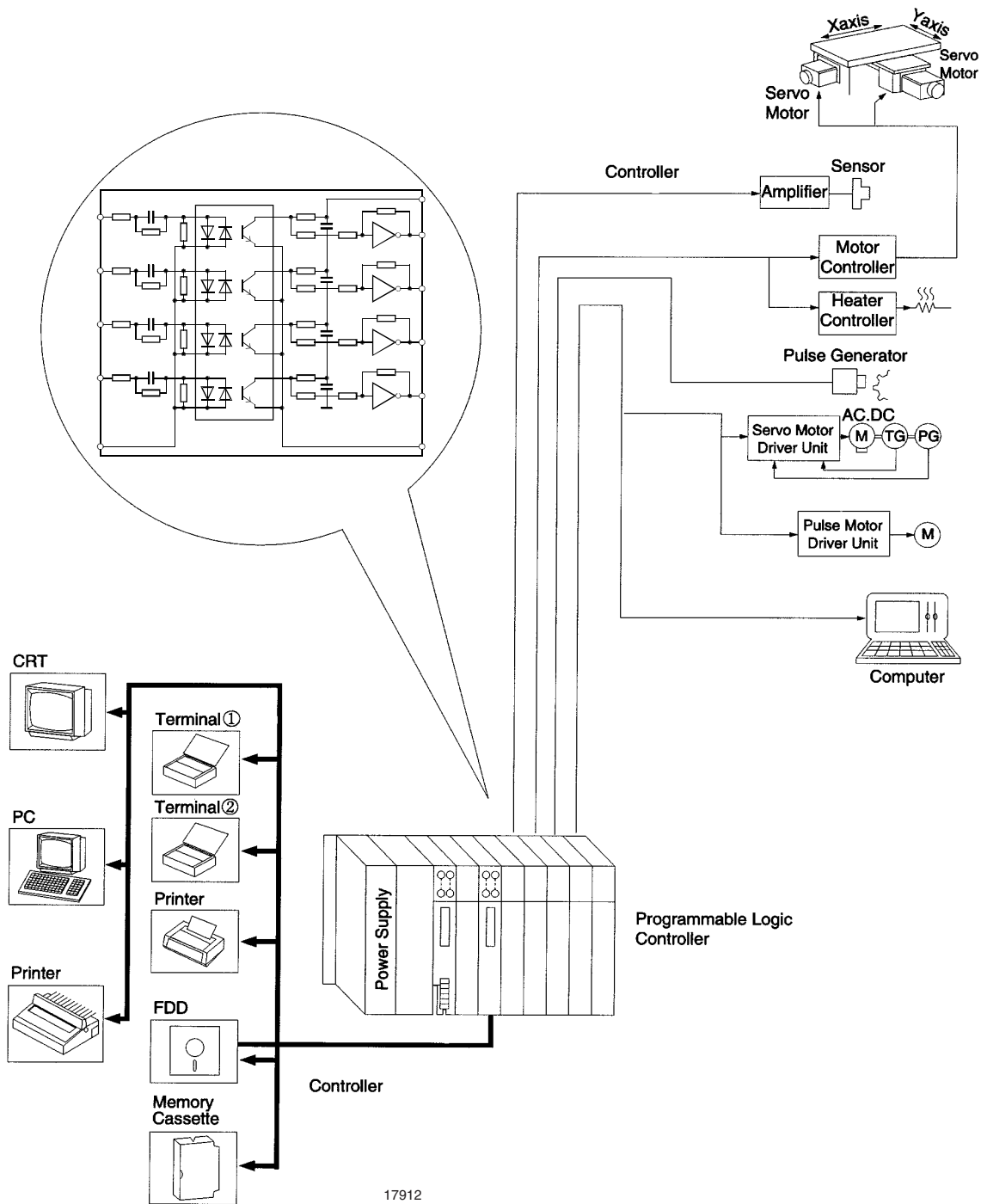

Figure 8. Conventional optocoupler (one-direction input)
(Full-wave rectified by diode bridge)

Programmable Logic Controller Example

Purpose: in-out interface



17912