



---

---

## Section 28. Analog-to-Digital Converter (ADC) without DMA

---

---

### HIGHLIGHTS

This section of the manual contains the following major topics:

28.1	Introduction .....	28-2
28.2	Control Registers .....	28-4
28.3	Sample Conversion Sequence .....	28-12
28.4	ADC Configuration .....	28-19
28.5	ADC Interrupt Generation .....	28-23
28.6	Analog Input Selection for Conversion.....	28-24
28.8	Analog-to-Digital Sampling Requirements .....	28-31
28.9	Transfer Function .....	28-33
28.10	Special Function Registers .....	28-35
28.11	Design Tips .....	28-36
28.12	Related Application Notes.....	28-37
28.13	Revision History .....	28-38

## 28.1 INTRODUCTION

This document describes the features and associated operational modes of the successive approximation (SAR) Analog-to-Digital Converter (ADC) available on the dsPIC33F family of devices. The ADC module can be configured by the user application to function as a 10-bit, 4-channel ADC or a 12-bit, single-channel ADC. Figure 28-1 shows a block diagram of the ADC module.

The dsPIC33F ADC module has the following key features:

- SAR conversion
- Up to one Msps conversion speed
- Up to 13 analog input pins
- External voltage reference input pins
- Four unipolar differential Sample/Hold amplifiers
- Simultaneous sampling of up to four analog input pins
- Automatic Channel Scan mode
- Selectable conversion trigger source
- 16-word conversion result buffer
- Selectable Buffer Fill modes
- Four result alignment options
- Operation during CPU Sleep and Idle modes

Depending on the device variant, the ADC module may have up to 13 analog input pins, designated AN0-AN12. These analog inputs are connected by multiplexers to four Sample/Hold amplifiers, designated CH0-CH3. The analog input multiplexers have two sets of control bits, designated as MUXA (CHySA/CHyNA) and MUXB (CHySB/CHyNB). These control bits select a particular analog input for conversion. The MUXA and MUXB control bits can alternatively select the analog input for conversion. Unipolar differential conversions are possible on all channels using certain input pins (refer to Figure 28-1).

Channel Scan mode can be enabled for the CH0 Sample/Hold amplifier. Any subset of the analog inputs (AN0 to AN12) can be selected by the user application. The selected inputs are converted in ascending order using CH0.

The ADC module supports simultaneous sampling using multiple Sample/Hold channels to sample the inputs at the same time, and then performs the conversion for each channel sequentially. By default, the multiple channels are sampled and converted sequentially.

The ADC module is connected to a 16-word result buffer. The ADC result is available in four different numerical formats (refer to Figure 28-11).

**Note 1:** A 'y' is used with MUXA and MUXB control bits to specify the Sample/Hold channel numbers (y = 0 or 123).

**2:** Depending on a particular device pinout, the ADC can have up to 13 analog input pins, designated AN0 through AN12. In addition, there are two analog input pins for external voltage reference connections (VREF+, VREF-). These voltage reference inputs can be shared with other analog input pins. The actual number of analog input pins and external voltage reference input configuration depends on the specific device. For further details, refer to the device data sheet.

# Section 28. Analog-to-Digital Converter (ADC) without DMA

Figure 28-1: ADC Block Diagram

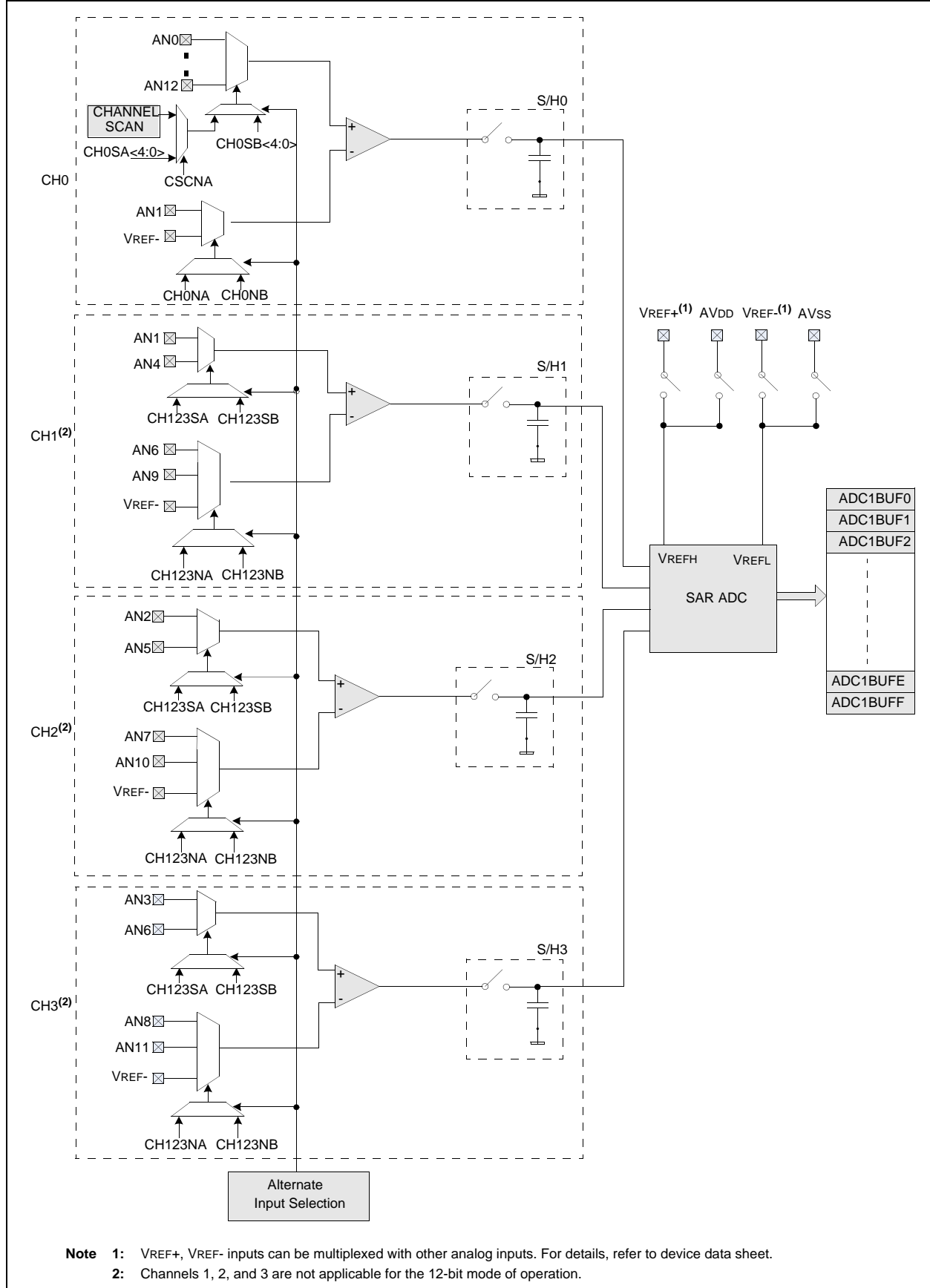

## 28.2 CONTROL REGISTERS

The ADC module has seven Control and Status registers. These registers are:

- **AD1CON1: ADC1 Control Register 1**
- **AD1CON2: ADC1 Control Register 2**
- **AD1CON3: ADC1 Control Register 3**
- **AD1CHS123: ADC1 Input Channel 1, 2, 3 Select Register**
- **AD1CHS0: ADC1 Input Channel 0 Select Register**
- **AD1CSSL: ADC1 Input Scan Select Register Low**
- **AD1PCFGL: ADC1 Port Configuration Register Low**

The AD1CON1, AD1CON2, and AD1CON3 registers control the operation of the ADC module. The AD1CHS0 and AD1CHS123 registers select the input pins to be connected to the Sample/Hold amplifiers. The AD1PCFGL register configures the analog input pins as analog inputs or as digital I/O. The AD1CSSL register selects inputs to be sequentially scanned.

### 28.2.1 ADC Result Buffer

The ADC module contains a 16-word dual port RAM, to buffer the ADC results. The 16 buffer locations are referred to as ADC1BUF0, ADC1BUF1, ADC1BUF2, ....., ADC1BUFE, ADC1BUFF.

# Section 28. Analog-to-Digital Converter (ADC) without DMA

**Register 28-1: AD1CON1: ADC1 Control Register 1**

R/W-0	U-0	R/W-0	U-0	U-0	R/W-0	R/W-0	R/W-0
ADON	—	ADSIDL	—	—	AD12B	FORM<1:0>	
bit 15						bit 8	
R/W-0	R/W-0	R/W-0	U-0	R/W-0	R/W-0	R/W-0	R/C-0
SSRC<2:0>			—	SIMSAM	ASAM	SAMP	DONE
bit 7						bit 0	

<b>Legend:</b>	HC = Cleared by hardware	HS = Set by hardware
R = Readable bit	W = Writable bit	U = Unimplemented bit, read as '0'
-n = Value at POR	'1' = Bit is set	'0' = Bit is cleared
		x = Bit is unknown

- bit 15      **ADON:** ADC Operating Mode bit  
1 = ADC module is operating  
0 = ADC module is off
- bit 14      **Unimplemented:** Read as '0'
- bit 13      **ADSIDL:** Stop in Idle Mode bit  
1 = Discontinue module operation when device enters Idle mode  
0 = Continue module operation in Idle mode
- bit 12-11   **Unimplemented:** Read as '0'
- bit 10      **AD12B:** 10-bit or 12-bit Operation Mode bit  
1 = 12-bit, 1-channel ADC operation  
0 = 10-bit, 4-channel ADC operation
- bit 9-8     **FORM<1:0>:** Data Output Format bits  
For 10-bit operation:  
11 = Signed fractional (DOUT = sddd dddd dd00 0000, where s = .NOT.d<9>)  
10 = Fractional (DOUT = dddd dddd dd00 0000)  
01 = Signed integer (DOUT = ssss sssd dddd dddd, where s = .NOT.d<9>)  
00 = Integer (DOUT = 0000 00dd dddd dddd)  
For 12-bit operation:  
11 = Signed fractional (DOUT = sddd dddd dddd 0000, where s = .NOT.d<11>)  
10 = Fractional (DOUT = dddd dddd dddd 0000)  
01 = Signed Integer (DOUT = ssss sddd dddd dddd, where s = .NOT.d<11>)  
00 = Integer (DOUT = 0000 dddd dddd dddd)
- bit 7-5     **SSRC<2:0>:** Sample Clock Source Select bits  
111 = Internal counter ends sampling and starts conversion (auto-convert)  
110 = Reserved  
101 = Reserved  
100 = Reserved  
011 = MPWM interval ends sampling and starts conversion  
010 = GP timer compare ends sampling and starts conversion  
001 = Active transition on INT0 pin ends sampling and starts conversion  
000 = Clearing sample bit ends sampling and starts conversion
- bit 4       **Unimplemented:** Read as '0'
- bit 3       **SIMSAM:** Simultaneous Sample Select bit (only applicable when CHPS<1:0> = 01 or 1x)  
**When AD12B = 1, SIMSAM is: U-0, Unimplemented, Read as '0'**  
1 = Samples CH0, CH1, CH2, CH3 simultaneously (when CHPS<1:0> = 1x); or  
    Samples CH0 and CH1 simultaneously (when CHPS<1:0> = 01)  
0 = Samples multiple channels individually in sequence
- bit 2       **ASAM:** ADC Sample Auto-Start bit  
1 = Sampling begins immediately after last conversion. SAMP bit is auto-set  
0 = Sampling begins when SAMP bit is set

# dsPIC33F Family Reference Manual

---

## Register 28-1: AD1CON1: ADC1 Control Register 1 (Continued)

- bit 1      **SAMP:** ADC Sample Enable bit  
1 = ADC Sample/Hold amplifiers are sampling  
0 = ADC Sample/Hold amplifiers are holding  
If ASAM = 0, software can write '1' to begin sampling. Automatically set by hardware if ASAM = 1.  
If SSRC = 000, software can write '0' to end sampling and start conversion. If SSRC ≠ 000, automatically cleared by hardware to end sampling and start conversion.
- bit 0      **DONE:** ADC Conversion Status bit  
1 = ADC conversion cycle is completed.  
0 = ADC conversion not started or in progress  
Automatically set by hardware when analog-to-digital conversion is complete. Software can write '0' to clear DONE status (software not allowed to write '1'). Clearing this bit does NOT affect any operation in progress. Automatically cleared by hardware at start of a new conversion.

# Section 28. Analog-to-Digital Converter (ADC) without DMA

**Register 28-2: AD1CON2: ADC1 Control Register 2**

R/W-0	R/W-0	R/W-0	U-0	U-0	R/W-0	R/W-0	R/W-0	
VCFG<2:0>			—	—	CSCNA	CHPS<1:0>		
bit 15								bit 8
R-0	U-0	R/W-0	R/W-0	R/W-0	R/W-0	R/W-0	R/W-0	
BUFS	—	SMPI<3:0>				BUFM	ALTS	
bit 7								bit 0

**Legend:**

R = Readable bit                      W = Writable bit                      U = Unimplemented bit, read as '0'  
 -n = Value at POR                      '1' = Bit is set                      '0' = Bit is cleared                      x = Bit is unknown

bit 15-13      **VCFG<2:0>**: Converter Voltage Reference Configuration bits

	VREFH	VREFL
000	AVDD	Avss
001	External VREF+	Avss
010	AVDD	External VREF-
011	External VREF+	External VREF-
1xx	AVDD	Avss

bit 12-11      **Unimplemented:** Read as '0'

bit 10      **CSCNA:** Input Scan Select bit

1 = Scan inputs using CH0  
 0 = Do not scan inputs

bit 9-8      **CHPS<1:0>**: Channel Select bits

When AD12B = 1, CHPS<1:0> is: U-0, Unimplemented, Read as '0'  
 1x = Converts CH0, CH1, CH2, and CH3  
 01 = Converts CH0 and CH1  
 00 = Converts CH0

bit 7      **BUFS:** Buffer Fill Status bit (only valid when BUFM = 1)

1 = ADC is currently filling the second half of the buffer. The user application should access data in the first half of the buffer  
 0 = ADC is currently filling the first half of the buffer. The user application should access data in the second half of the buffer

bit 6      **Unimplemented:** Read as '0'

bit 5-2      **SMPI<3:0>**: Samples Convert Sequences Per Interrupt

1111 = Interrupts at the completion of conversion for every 16th sample/convert sequence  
 1110 = Interrupts at the completion of conversion for every 15th sample/convert sequence  
 •  
 •  
 •  
 0001 = Interrupts at the completion of conversion for every 2nd sample/convert sequence  
 0000 = Interrupts at the completion of conversion for every sample/convert sequence

bit 1      **BUFM:** Buffer Fill Mode Select bit

1 = Starts buffer filling the first half of the buffer on the first interrupt and the second half of the buffer on next interrupt  
 0 = Always starts filling the buffer from the start address

bit 0      **ALTS:** Alternate Input Selection Mode Select bit

1 = MUXA and MUXB control bits alternatively select the analog input for conversion  
 0 = MUXA control bits select the analog input for conversion (CSCNA = 0)  
     Channel Scan Logic select the analog input for conversion (CSCNA = 1)

# dsPIC33F Family Reference Manual

**Register 28-3: AD1CON3: ADC1 Control Register 3**

R/W-0	U-0	U-0	R/W-0	R/W-0	R/W-0	R/W-0	R/W-0
ADRC	—	—	SAMC<4:0>				
bit 15							bit 8
R/W-0	R/W-0	R/W-0	R/W-0	R/W-0	R/W-0	R/W-0	R/W-0
ADCS<7:0>							
bit 7							bit 0

**Legend:**

R = Readable bit	W = Writable bit	U = Unimplemented bit, read as '0'
-n = Value at POR	'1' = Bit is set	'0' = Bit is cleared      x = Bit is unknown

bit 15      **ADRC: ADC Conversion Clock Source bit**  
 1 = ADC Internal RC Clock  
 0 = Clock derived from system clock

bit 14-13      **Unimplemented:** Read as '0'

bit 12-8      **SAMC<4:0>: Auto Sample Time bits**  
 11111 = 31 TAD  
 •  
 •  
 •  
 00001 = 1 TAD  
 00000 = 0 TAD

bit 7-0      **ADCS<7:0>: ADC Conversion Clock Select bits**  
 11111111 =  $T_{CY} \cdot (ADCS<7:0> + 1) = 256 \cdot T_{CY} = T_{AD}$   
 •  
 •  
 •  
 00000010 =  $T_{CY} \cdot (ADCS<7:0> + 1) = 3 \cdot T_{CY} = T_{AD}$   
 00000001 =  $T_{CY} \cdot (ADCS<7:0> + 1) = 2 \cdot T_{CY} = T_{AD}$   
 00000000 =  $T_{CY} \cdot (ADCS<7:0> + 1) = 1 \cdot T_{CY} = T_{AD}$



## Section 28. Analog-to-Digital Converter (ADC) without DMA

**Register 28-4: AD1CHS123: ADC1 Input Channel 1, 2, 3 Select Register**

U-0	U-0	U-0	U-0	U-0	R/W-0	R/W-0	R/W-0
—	—	—	—	—	CH123NB<1:0>		CH123SB
bit 15						bit 8	

U-0	U-0	U-0	U-0	U-0	R/W-0	R/W-0	R/W-0
—	—	—	—	—	CH123NA<1:0>		CH123SA
bit 7						bit 0	

**Legend:**

R = Readable bit	W = Writable bit	U = Unimplemented bit, read as '0'
-n = Value at POR	'1' = Bit is set	'0' = Bit is cleared      x = Bit is unknown

- bit 15-11      **Unimplemented:** Read as '0'
- bit 10-9      **CH123NB<1:0>:** Channel 1, 2, 3 Negative Input Select for Sample B bits  
 When AD12B = 1, CHxNB is: U-0, Unimplemented, Read as '0'  
 11 = CH1 negative input is AN9, CH2 negative input is AN10, CH3 negative input is AN11  
 10 = CH1 negative input is AN6, CH2 negative input is AN7, CH3 negative input is AN8  
 0x = CH1, CH2, CH3 negative input is VREF-
- bit 8          **CH123SB:** Channel 1, 2, 3 Positive Input Select for Sample B bit  
 When AD12B = 1, CHxSA is: U-0, Unimplemented, Read as '0'  
 1 = CH1 positive input is AN3, CH2 positive input is AN4, CH3 positive input is AN5  
 0 = CH1 positive input is AN0, CH2 positive input is AN1, CH3 positive input is AN2
- bit 7-3      **Unimplemented:** Read as '0'
- bit 2-1      **CH123NA<1:0>:** Channel 1, 2, 3 Negative Input Select for Sample A bits  
 When AD12B = 1, CHxNA is: U-0, Unimplemented, Read as '0'  
 11 = CH1 negative input is AN9, CH2 negative input is AN10, CH3 negative input is AN11  
 10 = CH1 negative input is AN6, CH2 negative input is AN7, CH3 negative input is AN8  
 0x = CH1, CH2, CH3 negative input is VREF-
- bit 0          **CH123SA:** Channel 1, 2, 3 Positive Input Select for Sample A bit  
 When AD12B = 1, CHxSA is: U-0, Unimplemented, Read as '0'  
 1 = CH1 positive input is AN3, CH2 positive input is AN4, CH3 positive input is AN5  
 0 = CH1 positive input is AN0, CH2 positive input is AN1, CH3 positive input is AN2

# dsPIC33F Family Reference Manual

**Register 28-5: AD1CHS0: ADC1 Input Channel 0 Select Register**

R/W-0	U-0	U-0	R/W-0	R/W-0	R/W-0	R/W-0	R/W-0
CH0NB	—	—	CH0SB<4:0>				
bit 15							bit 8
R/W-0	U-0	U-0	R/W-0	R/W-0	R/W-0	R/W-0	R/W-0
CH0NA	—	—	CH0SA<4:0>				
bit 7							bit 0

**Legend:**  
R = Readable bit                      W = Writable bit                      U = Unimplemented bit, read as '0'  
-n = Value at POR                      '1' = Bit is set                      '0' = Bit is cleared                      x = Bit is unknown

- bit 15            **CH0NB:** Channel 0 Negative Input Select for Sample B bit  
Same definition as bit 7.
- bit 14-13       **Unimplemented:** Read as '0'
- bit 12-8        **CH0SB<4:0>:** Channel 0 Positive Input Select for Sample B bits  
Same definition as bit<4:0>.
- bit 7            **CH0NA:** Channel 0 Negative Input Select for Sample A bit  
1 = Channel 0 negative input is AN1  
0 = Channel 0 negative input is VREF-
- bit 6-5         **Unimplemented:** Read as '0'
- bit 4-0         **CH0SA<4:0>:** Channel 0 Positive Input Select for Sample A bits<sup>(1)</sup>  
01100 = Channel 0 positive input is AN12  
01011 = Channel 0 positive input is AN11  
•  
•  
•  
00010 = Channel 0 positive input is AN2  
00001 = Channel 0 positive input is AN1  
00000 = Channel 0 positive input is AN0

**Note 1:** Not all inputs are present on all devices.

**Register 28-6: AD1CSSL: ADC1 Input Scan Select Register Low**

U-0	U-0	U-0	R/W-0	R/W-0	R/W-0	R/W-0	R/W-0
—	—	—	CSS12	CSS11	CSS10	CSS9	CSS8
bit 15							bit 8
R/W-0	R/W-0	R/W-0	R/W-0	R/W-0	R/W-0	R/W-0	R/W-0
CSS7	CSS6	CSS5	CSS4	CSS3	CSS2	CSS1	CSS0
bit 7							bit 0

**Legend:**  
R = Readable bit                      W = Writable bit                      U = Unimplemented bit, read as '0'  
-n = Value at POR                      '1' = Bit is set                      '0' = Bit is cleared                      x = Bit is unknown

- bit 12-0        **CSS<12:0>:** ADC Input Scan Selection bits<sup>(1)</sup>  
1 = Select ANx for input scan  
0 = Skip ANx for input scan

**Note 1:** On devices with less than 13 analog inputs, all AD1CSSL bits can be selected by the user application; however, inputs selected for scan without a corresponding input on device convert VREF-.

## Section 28. Analog-to-Digital Converter (ADC) without DMA

**Register 28-7: AD1PCFGL: ADC1 Port Configuration Register Low**

U-0	U-0	U-0	R/W-0	R/W-0	R/W-0	R/W-0	R/W-0	
—	—	—	PCFG12	PCFG11	PCFG10	PCFG9	PCFG8	
bit 15								bit 8
R/W-0	R/W-0	R/W-0	R/W-0	R/W-0	R/W-0	R/W-0	R/W-0	
PCFG7	PCFG6	PCFG5	PCFG4	PCFG3	PCFG2	PCFG1	PCFG0	
bit 7								bit 0

**Legend:**

R = Readable bit                      W = Writable bit                      U = Unimplemented bit, read as '0'  
 -n = Value at POR                      '1' = Bit is set                      '0' = Bit is cleared                      x = Bit is unknown

bit 12-0      **PCFG<12:0>**: ADC Port Configuration Control bits<sup>(1, 2)</sup>  
                   1 = Port pin in Digital mode, port read input enabled, ADC input multiplexor connected to AVss  
                   0 = Port pin in Analog mode, port read input disabled, ADC samples pin voltage

- Note 1:** On devices with less than 13 analog inputs, all PCFG bits are R/W by user application; however, PCFG bits are ignored on ports without a corresponding input on device.
- 2:** On devices with two Analog-to-Digital modules, both AD1PCFGL and AD2PCFGL affect the configuration of port pins multiplexed with AN0-AN12.

## 28.3 SAMPLE CONVERSION SEQUENCE

Figure 28-2 shows that the Analog-to-Digital conversion is a three step process:

1. The input voltage signal is connected to the sample capacitor.
2. The sample capacitor is disconnected from the input.
3. The stored voltage is converted to equivalent digital bits. The two distinct phases are independently controlled.

**Figure 28-2: Sample Conversion Sequence**

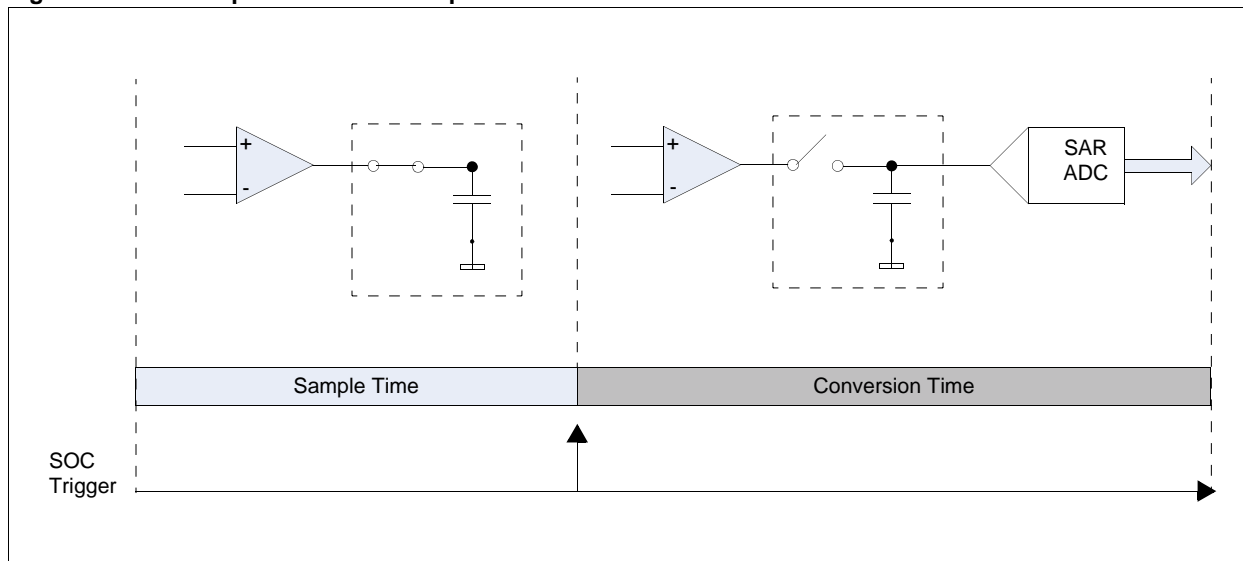

### 28.3.1 Sample Time

Sample Time is when the selected analog input is connected to the sample capacitor. There is a minimum sample time to ensure that the Sample/Hold amplifier provides a desired accuracy for the analog-to-digital conversion (refer to **28.8 “Analog-to-Digital Sampling Requirements”**).

The sampling phase can be set up to start automatically upon conversion or by manually setting the Sample (SAMP<1>) bit in the ADC Control register (AD1CON1<1>). The sampling phase is controlled by the Auto-Sample (ASAM<2>) bit in the ADC Control register (AD1CON1<2>). Table 28-1 lists the options selected by the specific bit configuration.

**Table 28-1: Start of Sampling Selection**

ASAM	Start of sampling selection
0	Manual sampling
1	Automatic sampling

## 28.3.2 Conversion Time

The Start of Conversion (SOC) trigger ends the sampling time and begins an analog-to-digital conversion. During the conversion period, the sample capacitor is disconnected from the multiplexer, and the stored voltage is converted to equivalent digital bits. The conversion time for 10-bit and 12-bit modes are shown in Equation 28-1 and Equation 28-2. The sum of the sample time and the analog-to-digital conversion time provide the total conversion time.

**Equation 28-1: 10-bit ADC Conversion Time**

$$\text{Conversion Time} = 12 \cdot T_{AD}$$

Where:  
 $T_{AD}$  = ADC Clock Period

**Equation 28-2: 12-bit ADC Conversion Time**

$$\text{Conversion Time} = 14 \cdot T_{AD}$$

Where:  
 $T_{AD}$  = ADC Clock Period

The SOC trigger can be taken from a variety of hardware sources or controlled manually in user software. The trigger source to initiate conversion is selected by the SOC Trigger Source Select bits (SSRC<2:0>) in the ADC Control register (AD1CON1<7:5>). Table 28-2 lists the conversion trigger source selection for different bit settings.

**Table 28-2: SOC Trigger Selection**

SSRC<2:0>	SOC Trigger Source
000	Manual Trigger
001	External Interrupt Trigger (INT0)
010	Timer Interrupt Trigger
011	Motor Control PWM Special Event Trigger
100	Reserved
101	Reserved
110	Reserved
111	Automatic Trigger

Table 28-3 lists the sample conversion sequence with different sample and conversion phase selections.

**Table 28-3: Sample Conversion Sequence Selection**

ASAM	SSRC<2:0>	Description
0	000	Manual Sample and Manual Conversion Sequence
0	111	Manual Sample and Automatic Conversion Sequence
0	001 010 011	Manual Sample and Triggered Conversion Sequence
1	000	Automatic Sample and Manual Conversion Sequence
1	111	Automatic Sample and Automatic Conversion Sequence
1	001 101 011	Automatic Sample and Triggered Conversion Sequence

## 28.3.3 Manual Sample and Manual Conversion Sequence

In both the Manual Sample and Manual Conversion Sequence, setting the Sample (SAMP<1>) bit in the ADC Control register (AD1CON1<1>) initiates sampling, and clearing the SAMP bit terminates sampling and starts conversion (refer to Figure 28-3). The user application must time the setting and clearing of the SAMP bit to ensure adequate sampling time for the input signal. Example 28-1 shows a code sequence for Manual Sample and Manual Conversion.

Figure 28-3: Manual Sample and Manual Conversion Sequence

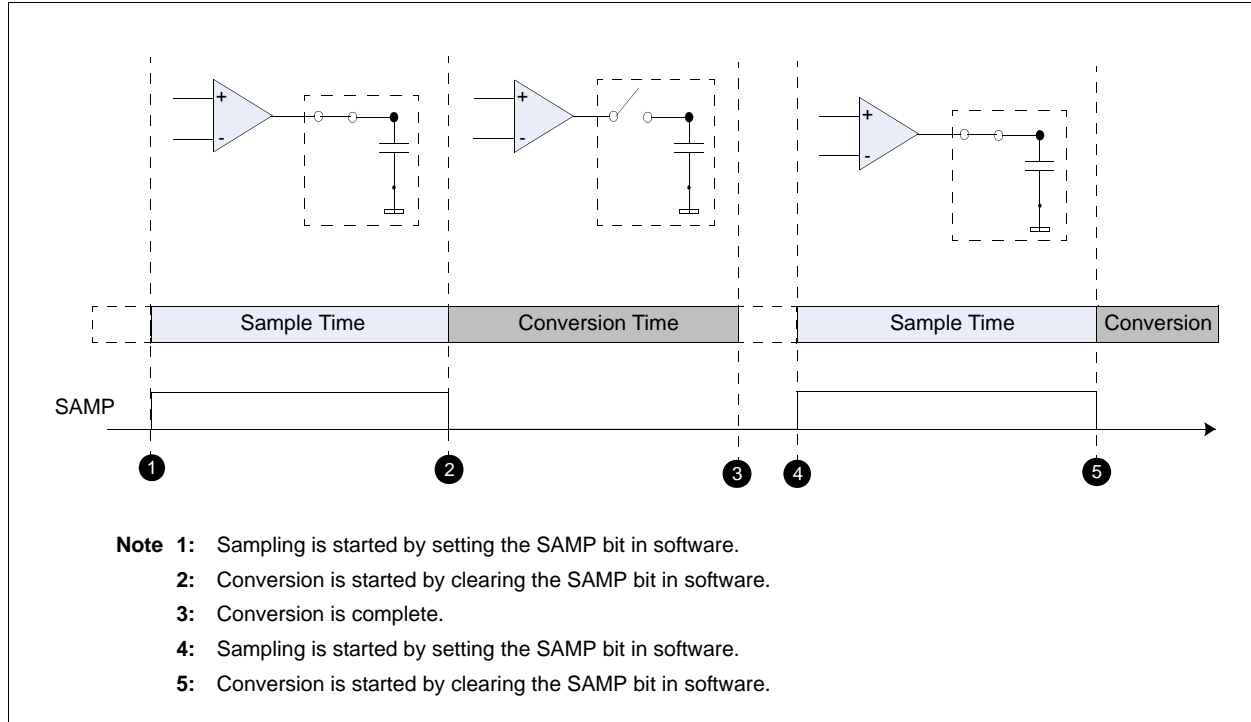

Example 28-1: Code Sequence for Manual Sample and Manual Conversion

```
AD1CON1bits.SAMP = 1;      // start sampling
DelayUs(10);              // wait for sampling time (10us)
AD1CON1bits.SAMP = 0;     // start the conversion
while (!AD1CON1bits.DONE); // wait for the conversion to complete
ADCValue = ADC1BUF0;      // read the conversion result
```

## 28.3.4 Automatic Sample and Automatic Conversion Sequence

The Auto Conversion method provides a more automated process to sample and convert the analog inputs as shown in Figure 28-4. The sampling period is self-timed and the conversion starts automatically upon termination of a self-timed sampling period. The Auto Sample Time (SAMC<4:0>) bits in the AD1CON3 register (AD1CON3<12:8>) select 0 to 31 ADC clock cycles (TAD) for sampling period.

Figure 28-4: Automatic Sample and Automatic Conversion Sequence

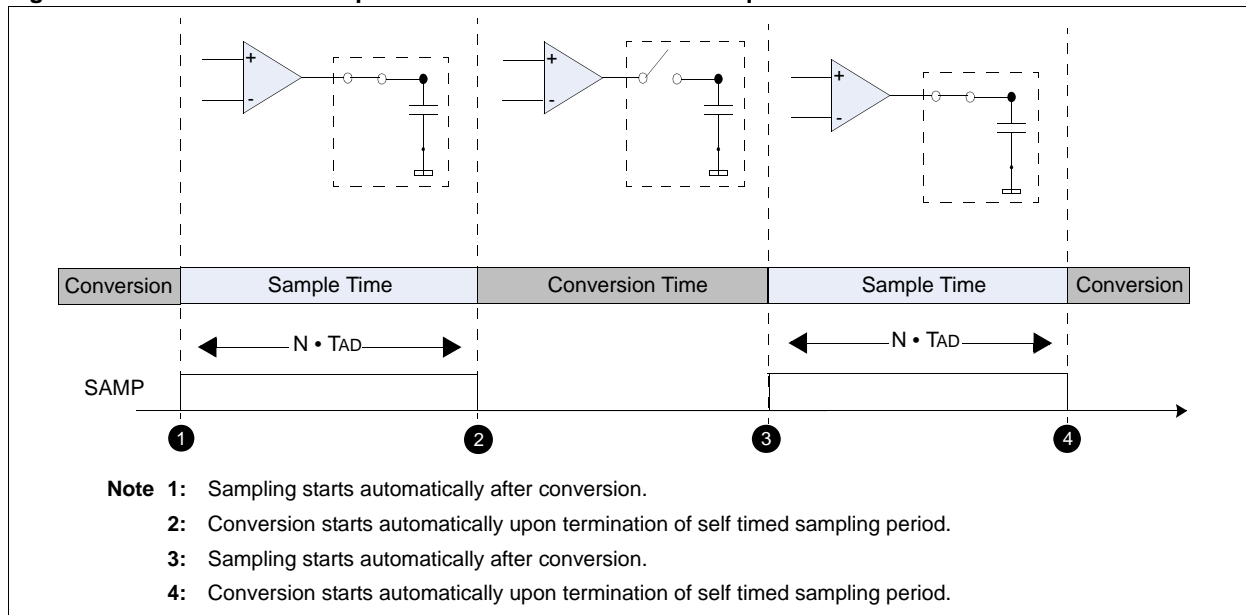

## 28.3.5 Automatic Sample and Triggered Conversion Sequence

In an automatic sample and triggered conversion sequence, the sampling starts automatically after conversion and the conversion is started upon trigger event from the selected peripheral (refer to Figure 28-5). This allows ADC conversion to be synchronized with the internal or external events.

Figure 28-5: Automatic Sample and Triggered Conversion Sequence

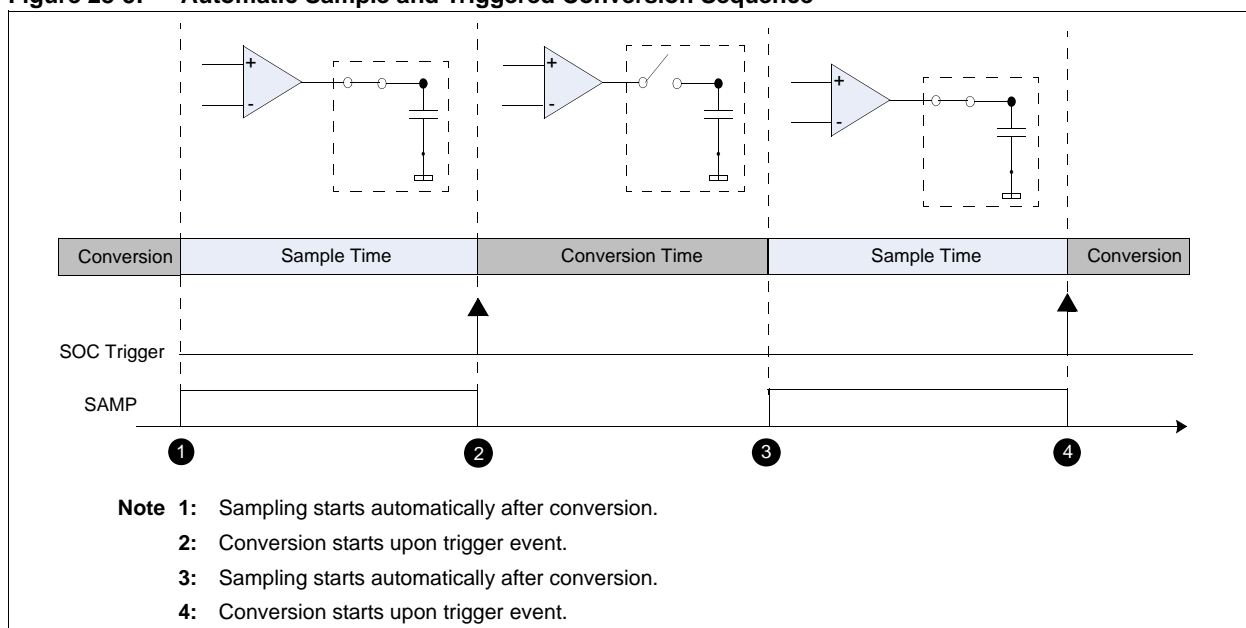

## 28.3.6 Multi-Channel Sample Conversion Sequence

Multi-channel analog-to-digital converters typically convert each input channel sequentially using an input multiplexer. Certain applications require simultaneous sampling, especially when phase information exists between different channels. For example, motor control and power monitoring requires voltage and current measurements and the phase angle between them. Figure 28-6 and Figure 28-7 show the ADC module supports simultaneous sampling using two Sample/Hold or four Sample/Hold channels to sample the inputs at the same instant and then perform the conversion for each channel sequentially.

The Simultaneous Sampling mode is selected by setting Simultaneous Sampling (SIMSAM<3>) bit in the ADC Control register (AD1CON1<3>). By default, the multiple channels are sampled and converted sequentially. Table 28-4 lists the options selected by a specific bit configuration.

**Table 28-4: Start of Sampling Selection**

SIMSAM	Sampling Mode
0	Sequential sampling
1	Simultaneous sampling

**Figure 28-6: 2-Channel Simultaneous Sampling (ASAM = 1)**

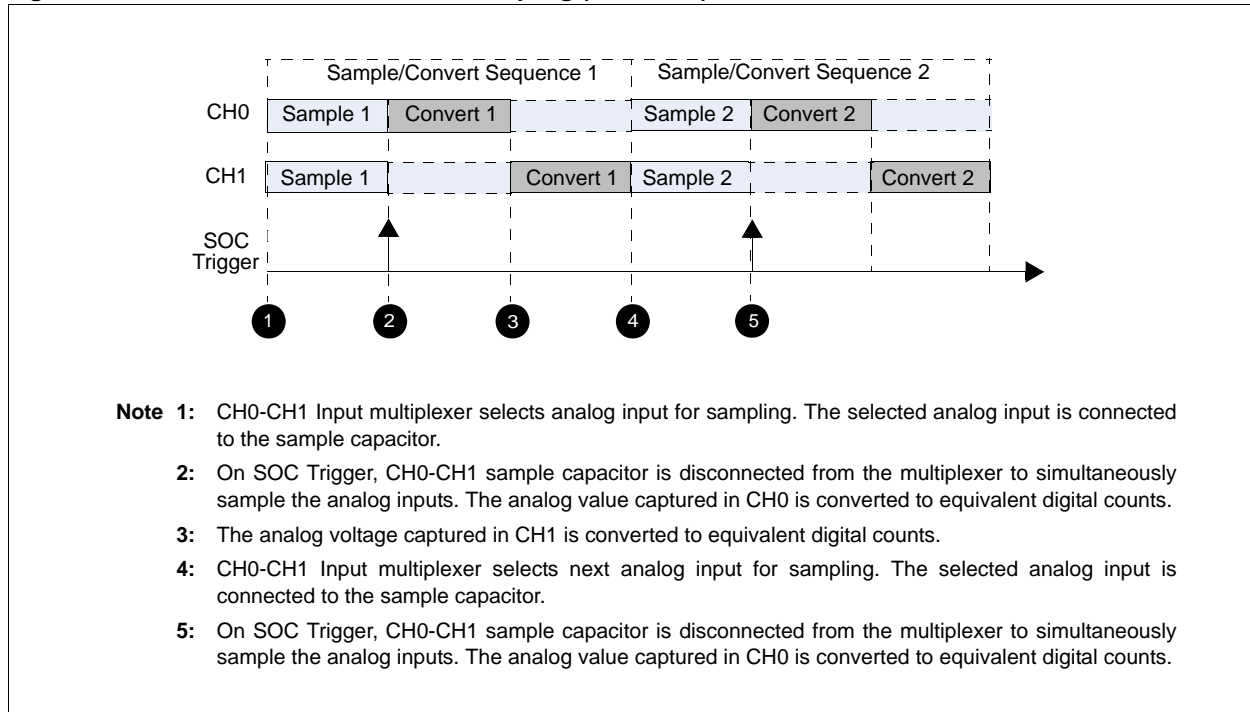



# Section 28. Analog-to-Digital Converter (ADC) without DMA

**Figure 28-7: 4-Channel Simultaneous Sampling**

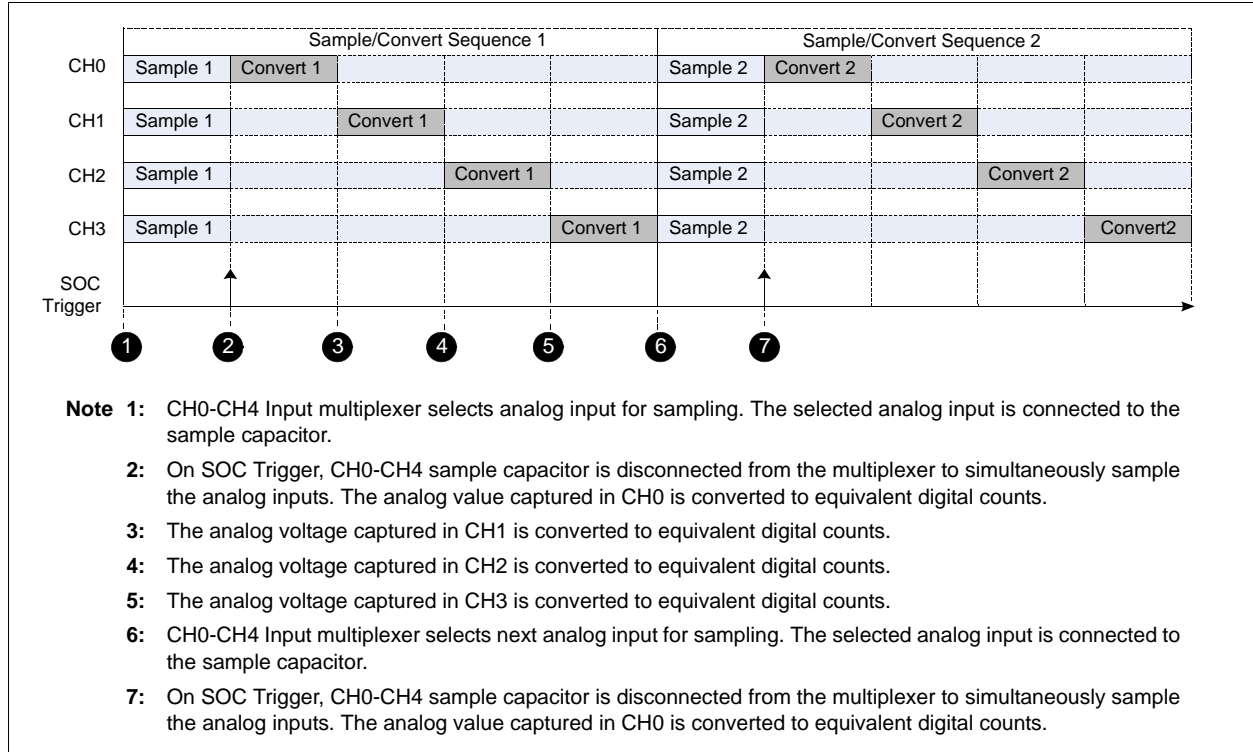
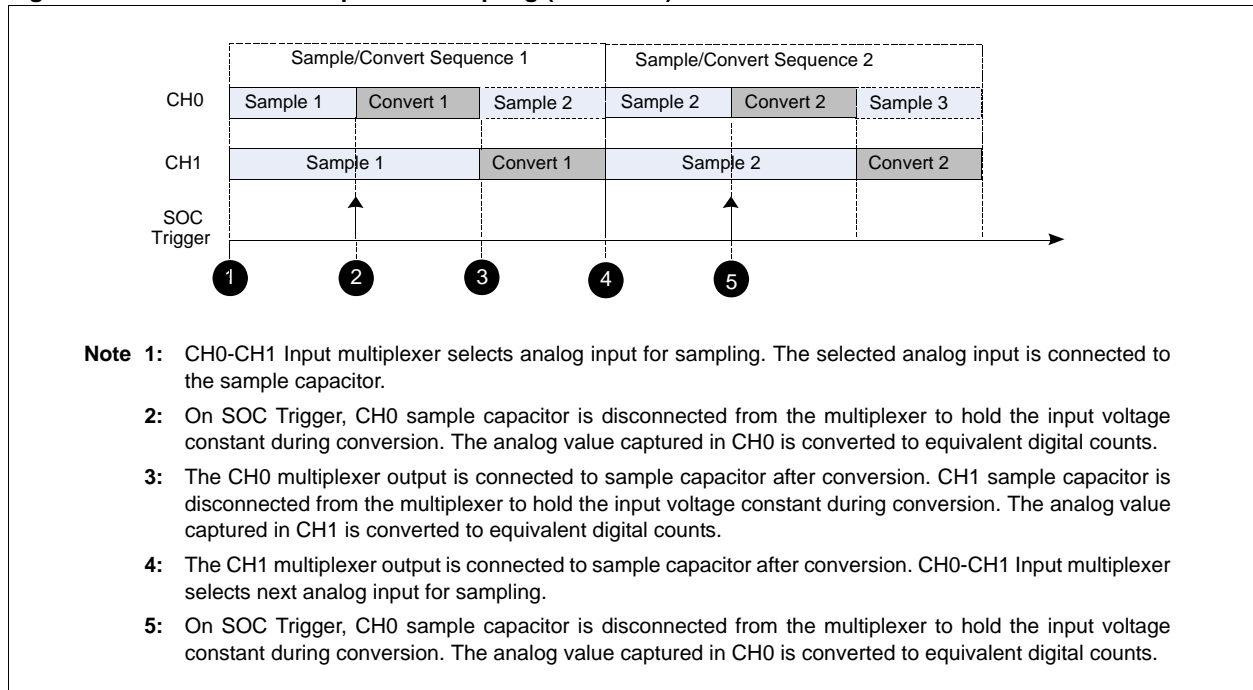

Figure 28-8 and Figure 28-9 show that by default, the multiple channels are sampled and converted sequentially.

**Figure 28-8: 2-Channel Sequential Sampling (ASAM = 1)**



# dsPIC33F Family Reference Manual

**Figure 28-9: 4-Channel Sequential Sampling**

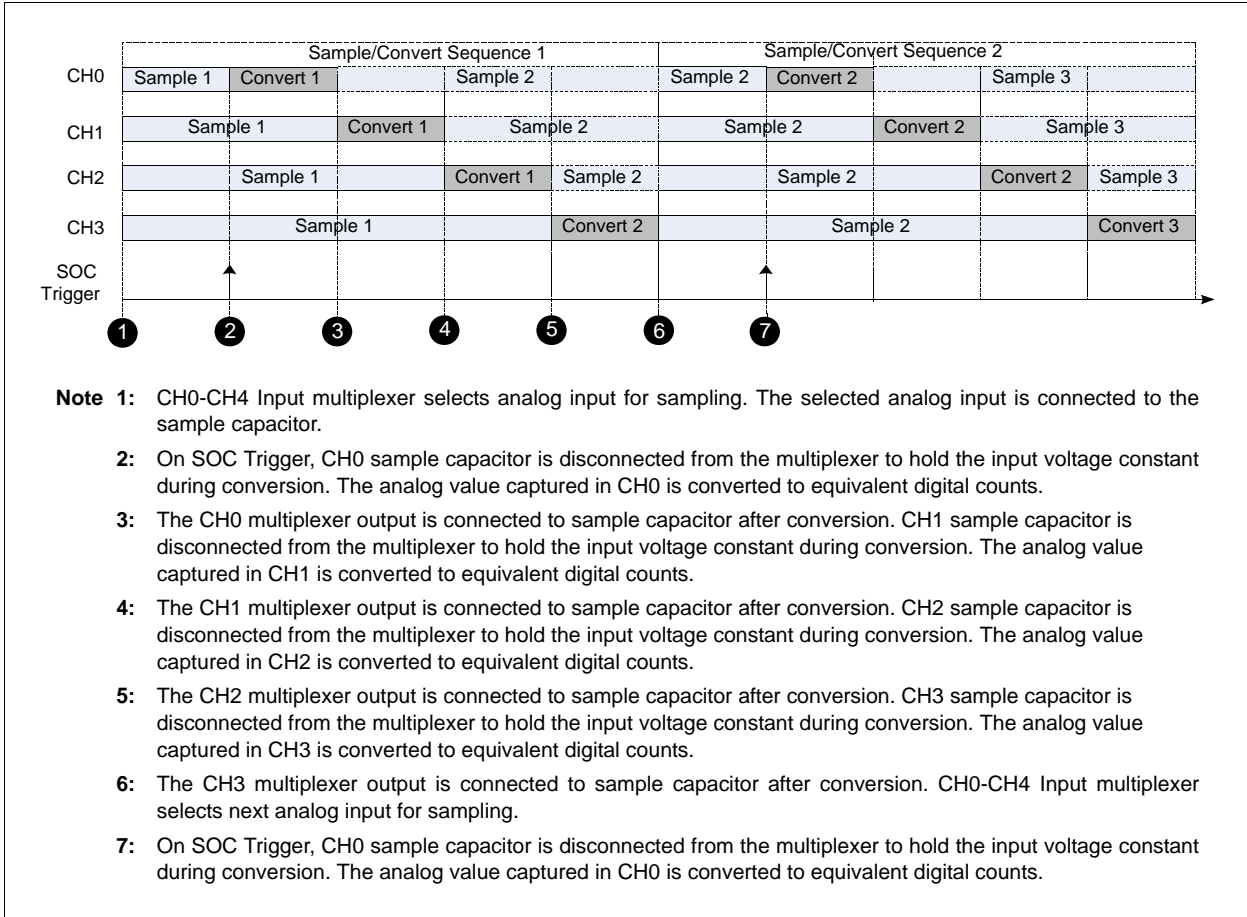

# Section 28. Analog-to-Digital Converter (ADC) without DMA

## 28.4 ADC CONFIGURATION

### 28.4.1 ADC Operational Mode Selection

The 12-bit Operation Mode (AD12B<10>) bit in the ADC Control register (AD1CON1<10>) allows the ADC module to function as either a 10-bit, 4-channel ADC (default configuration) or a 12-bit, single-channel ADC. Table 28-5 lists the options selected by different bit settings.

**Note:** The ADC module needs to be disabled before the AD12B bit is modified.

**Table 28-5: ADC Operational Mode**

AD12B	Channel Selection
0	10-bit, 4-channel ADC
1	12-bit, single-channel ADC

### 28.4.2 ADC Channel Selection

In 10-bit mode (AD12B = 0), the user application can select 1-channel, 2-channel, or 4-channel mode using the Channel Select bits (CHPS<1:0>) in the ADC Control register (AD1CON2<9:8>). Table 2 lists the number of channels selected for the different bit settings.

**Table 28-6: 10-bit ADC Channel Selection**

CHPS<1:0>	Channel Selection
00	CH0
01	Dual Channel (CH0, CH1)
1x	Multi-Channel (CH0-CH3)

### 28.4.3 Voltage Reference Selection

The voltage references for analog-to-digital conversions are selected using the Voltage Reference Configuration (VCFG<2:0>) bits in the ADC Control register (AD1CON2<15:13>). The voltage reference high (VREFH) and the voltage reference low (VREFL) to the ADC module can be supplied from the internal AVDD and AVSS voltage rails or the external VREF+ and VREF- input pins. The external voltage reference pins can be shared with the AN0 and AN1 inputs on low pin count devices. The ADC module can still perform conversions on these pins when they are shared with the VREF+ and VREF- input pins. The voltages applied to the external reference pins must meet certain specifications. For details, refer to the "Electrical Specifications" section of the device data sheet.

**Table 28-7: Voltage Reference Selection**

VCFG<2:0>	VREFH	VREFL
000	AVDD	AVSS
001	VREF+	AVSS
010	AVDD	VREF-
011	VREF+	VREF-
1xx	AVDD	AVSS

## 28.4.4 ADC Clock Selection

The ADC module can be clocked from the instruction cycle clock (TCY) or by using the dedicated internal RC clock (see Figure 7). When using the instruction cycle clock, a clock divider drives the instruction cycle clock and allows a lower frequency to be chosen. The clock divider is controlled by the ADC Conversion Clock Select (ADCS<7:0>) bits in the ADC Control register (AD1CON3<5:0>), which allows 256 settings, from 1:1 to 1:256, to be chosen.

Equation 28-3 shows the ADC Clock period (TAD) as a function of the ADCS control bits and the device instruction cycle clock period, TCY.

**Equation 28-3: ADC Clock Period**

$$ADC\ Clock\ Period\ (TAD) = TCY \cdot (ADCS + 1)$$

The ADC module has a dedicated internal RC clock source that can be used to perform conversions. The internal RC clock source is used when analog-to-digital conversions are performed while the device is in Sleep mode. The internal RC oscillator is selected by setting the ADC Conversion Clock Source (ADRC<15>) bit in the ADC Control register (AD1CON3<15>). When the ADRC bit is set, the ADCS<7:0> bits have no effect on the ADC operation.

**Figure 28-10: ADC Clock Generation**

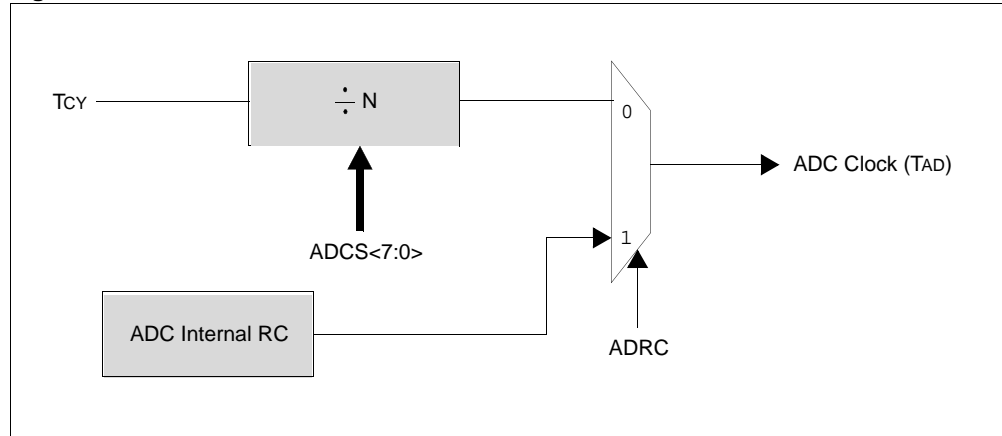

## 28.4.5 Output Data Format Selection

Figure 28-11 shows the ADC result is available in four different numerical formats. The Data Output Format (FORM<1:0>) bits in the ADC Control register (AD1CON1<9:8>) select the output data format. Table 28-8 lists the ADC output format for different bit settings.

**Table 28-8: Voltage Reference Selection**

FORM<1:0>	Data Information Selection
11	Signed Fractional Format
10	Unsigned Fractional format
01	Signed Integer format
00	Unsigned Integer format

# Section 28. Analog-to-Digital Converter (ADC) without DMA

Figure 28-11: ADC Output Format

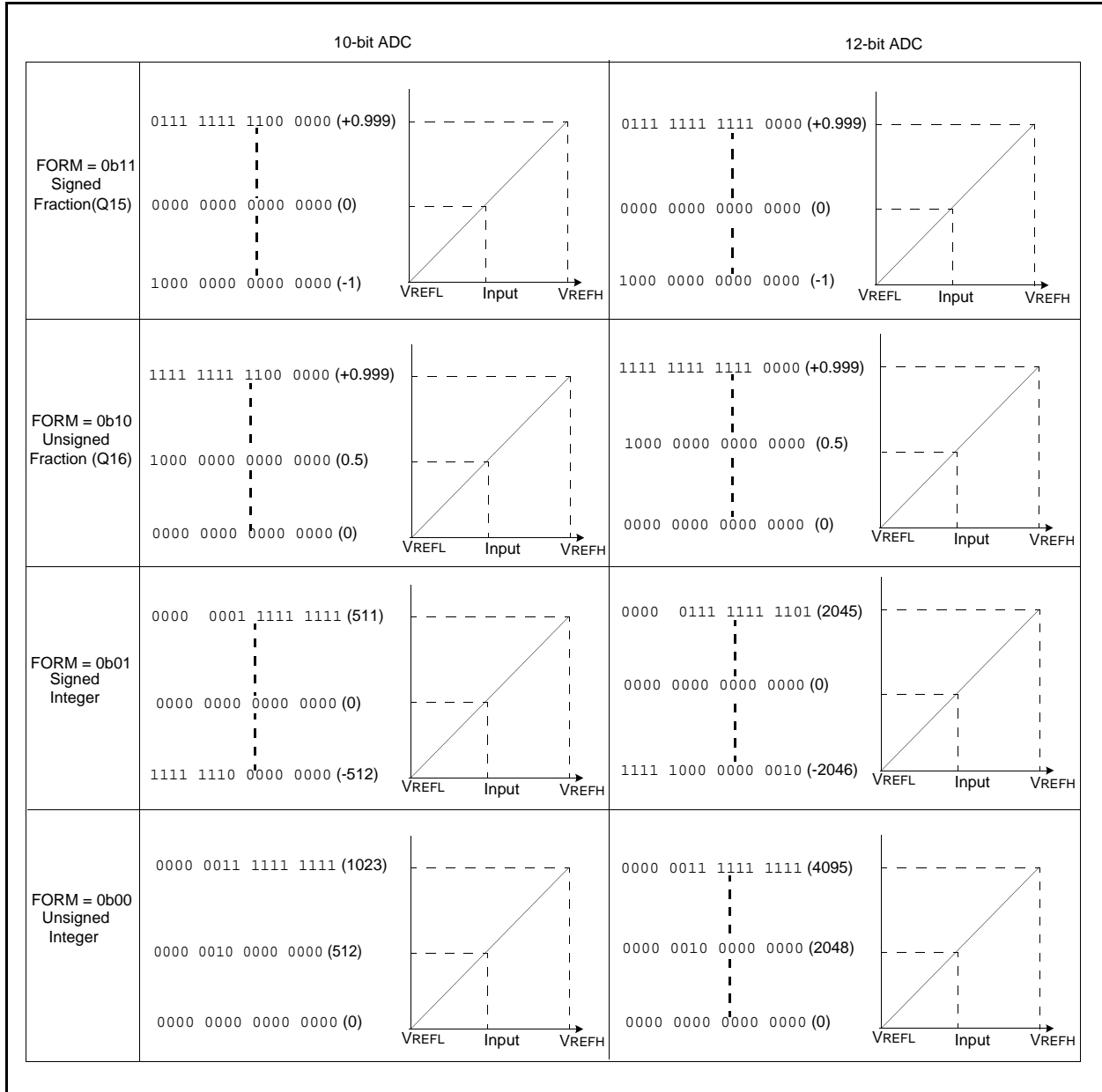

## 28.4.6 Configuring Analog Port Pins

The Analog/Digital Pin Configuration register (AD1PCFGL) specifies the input condition of device pins used as analog inputs. Along with the Data Direction (TRISx) register in the Parallel I/O Port module, these registers control the operation of the ADC pins.

A pin is configured as an analog input when the corresponding PCFGn bit (AD1PCFGL<n>) is clear. The AD1PCFGL register is cleared at Reset, causing the ADC input pins to be configured for analog input by default at Reset.

When configured for analog input, the associated port I/O digital input buffer is disabled so that it does not consume current.

The port pins that are desired as analog inputs must have their corresponding TRIS bit set, specifying the port input. If the I/O pin associated with an analog-to-digital input is configured as an output, the TRIS bit is cleared and the digital output level (VOH or VOL) of the port is converted. After a device Reset, all TRIS bits are set.

A pin is configured as a digital I/O when the corresponding PCFGn bit is set. In this configuration, the input to the analog multiplexer is connected to AVSS.

**Note 1:** When the ADC Port register is read, any pin configured as an analog input reads as a '0'.

**2:** Analog levels on any pin that is defined as a digital input may cause the input buffer to consume current that is out of the device specification.

## 28.4.7 Enabling the ADC Module

When the ADON bit (AD1CON1<15>) is '1', the module is in Active mode and is fully powered and functional.

When ADON is '0', the module is disabled. The digital and analog portions of the circuit are turned off for maximum current savings.

To return to the Active mode from the Off mode, the user application must wait for the analog stages to stabilize. For the stabilization time, refer to the "Electrical Characteristics" section of the device data sheet.

**Note:** The SSRC<2:0>, SIMSAM, ASAM, CHPS<1:0>, SMPI<3:0>, BUFM, and ALTS bits, as well as the ADCON3 and ADCSSL registers, should not be written to while ADON = 1. This would lead to indeterminate results.

## 28.5 ADC INTERRUPT GENERATION

As conversions are completed, the ADC module writes the results of the conversions into the analog-to-digital result buffer. The ADC result buffer is an array of sixteen words, accessed through the SFR space. The user application may attempt to read each analog-to-digital conversion result as it is generated. However, this might consume too much CPU time. Generally, to simplify the code, the module fills the buffer with results and generates an interrupt when the buffer is filled. The ADC module supports 16 result buffers. Therefore, the maximum number of conversions per interrupt must not exceed 16.

The number of conversion per ADC interrupt depends on the following parameters, which can vary from one to 16 conversions per interrupt.

- Number of Sample/Hold channels selected
- Sequential or Simultaneous Sampling
- Samples Convert Sequences Per Interrupt (SMPI<3:0>) bit settings

Table 28-9 lists the number of conversions per ADC interrupt for different configuration modes.

**Table 28-9: Samples Per Interrupt in Alternate Sampling Mode**

CHPS<1:0>	SIMSAM	SMPI<3:0>	Conversions/Interrupt	Description
00	x	N-1	N	1-Channel mode
01	0	N-1	N	2-Channel Sequential Sampling mode
1x	0	N-1	N	4-Channel Sequential Sampling mode
01	1	N-1	2 • N	2-Channel Simultaneous Sampling mode
1x	1	N-1	4 • N	4-Channel Simultaneous Sampling mode

**Note 1:** In 2-channel Simultaneous Sampling mode, SMPI<3:0> bit settings must be less than eight.

**2:** In 4-channel Simultaneous Sampling mode, SMPI<3:0> bit settings must be less than four.

The DONE bit (AD1CON1<0>) is set when an ADC interrupt is generated to indicate completion of a required sample/conversion sequence. This bit is automatically cleared by the hardware at the beginning of the next sample/conversion sequence.

### 28.5.1 Buffer Fill Mode

When the Buffer Fill mode (BUFM<1>) bit in the ADC Control register (AD1CON2<1>) is '1', the 16-word results buffer is split into two 8-word groups: a lower group (ADC1BUF0 through ADC1BUF7) and an upper group (ADC1BUF8 through ADC1BUFF). The 8-word buffers alternately receive the conversion results after each ADC interrupt event. When the BUFM bit is set, each buffer size is equal to eight. Therefore, the maximum number of conversions per interrupt must not exceed eight.

When the BUFM bit is '0', the complete 16-word buffer is used for all conversion sequences. The decision to use the split buffer feature depends on the time available to move the buffer contents, after the interrupt, as determined by the application.

If the application can quickly unload a full buffer within the time taken to sample and convert one channel, the BUFM bit can be '0', and up to 16 conversions may be done per interrupt. The application has one sample/convert time before the first buffer location is overwritten. If the processor cannot unload the buffer within the sample and conversion time, the BUFM bit should be '1'. For example, if an ADC interrupt is generated every eight conversions, the processor has the entire time between interrupts to move the eight conversions out of the buffer.

### 28.5.2 Buffer Fill Status

When the conversion result buffer is split using the BUFM control bit, the BUFS status bit (AD1CON2<7>) indicates, half of the buffer that the ADC module is currently writing. If BUFS = 0, the ADC module is filling the lower group, and the user application should read conversion values from the upper group. If BUFS = 1, the situation is reversed, and the user application should read conversion values from the lower group.

## 28.6 ANALOG INPUT SELECTION FOR CONVERSION

The ADC module provides a flexible mechanism to select analog inputs for conversion:

- Fixed input selection
- Alternate input selection
- Channel scanning (CH0 only)

### 28.6.1 Fixed Input Selection

The 10-bit ADC configuration can use up to four Sample/Hold channels, designated CH0-CH3, whereas the 12-bit ADC configuration can use only one Sample/Hold channel, CH0. The Sample/Hold channels are connected to the analog input pins through the analog multiplexer. The analog input multiplexer is controlled by the AD1CHS123 and AD1CHS0 registers. There are two sets of control bits designated as MUXA (CHySA/CHyNA) and MUXB (CHySB/CHyNB) to select a particular input source for conversion. The MUXB control bits are used in Alternate Input Selection mode. By default, the MUXA bits select the analog input for conversion.

**Table 28-10: Analog Input Selection**

		MUXA		MUXB	
		Control bits	Analog Inputs	Control bits	Analog Inputs
CH0	+ve	CH0SA<4:0>	AN0 to AN12	CH0SB<4:0>	AN0 to AN12
	-ve	CH0NA	VREF-, AN1	CH0NB	AN0 to AN12
CH1	+ve	CH123SA	AN0, AN3	CH123SB	AN0, AN3
	-ve	CH123NA<1:0>	AN6, AN9, VREF-	CH123NB<1:0>	AN6, AN9, VREF-
CH2	+ve	CH123SA	AN1, AN4	CH123SB	AN1, AN4
	-ve	CH123NA<1:0>	AN7, AN10, VREF-	CH123NB<1:0>	AN7, AN10, VREF-
CH3	+ve	CH123SA	AN2, AN5	CH123SB	AN2, AN5
	-ve	CH123NA<1:0>	AN8, AN11, VREF-	CH123NB<1:0>	AN8, AN11, VREF-

**Note:** Not all inputs are present on all devices.

Example 28-2 shows the code sequence to set up ADC inputs for a 4-channel ADC configuration.

**Example 28-2: Code Sequence to Set Up ADC Inputs**

```
// Initialize MUXA Input Selection
AD1CHS0bits.CH0SA = 3;    // Select AN3 for CH0 +ve input
AD1CHS0bits.CH0NA = 0;    // Select VREF- for CH0 -ve input

AD1CHS123bits.CH123SA=0;  // Select AN0 for CH1 +ve input
                        // Select AN1 for CH2+ve input
                        // Select AN2 for CH3 +ve input
AD1CHS123bits.CH124NA=0;  // Select VREF- for CH1/CH2/CH3 -ve inputs
```



# Section 28. Analog-to-Digital Converter (ADC) without DMA

## 28.6.2 Alternate Input Selection mode

In an Alternate Input Selection mode, the MUXA and MUXB control bits select the channel for conversion. The ADC completes one sweep using the MUXA selection, and then another sweep using the MUXB selection, and then another sweep using the MUXA selection, and so on. The Alternate Input Selection mode is enabled by setting the Alternate Sample (ALTS<0>) bit in the ADC control register (AD1CON2<0>).

For Alternate Input Selection mode, an ADC interrupt must be generated after an even number of sample/conversion sequences by programming the Samples Convert Sequences Per Interrupt (SMPI<3:0>)bits. Table 28-11 shows the valid SMPI values for Alternate Input Selection mode in different ADC configurations.

Table 28-11: Valid SMPI Values for Alternate Input Selection Mode

CHPS<1:0>	SIMSAM	SMPI<3:0> (Decimal)	Conversions /Interrupt	Description
00	x	1,3,5,7,9,11,13,15	2,4,6,8,10,12,14,16	1- Channel mode
01	0	3,7,11,15	4,8,12,16	2- Channel Sequential Sampling mode
1x	0	7,15	8,16	4- Channel Sequential Sampling mode
01	1	1,3,5,7	4,8,12,16	2- Channel Simultaneous Sampling mode
1x	1	1,3	8,16	4- Channel Simultaneous Sampling mode

Example 28-3 shows the code sequence to set up the ADC module for Alternate Input Selection mode in the 4-Channel Simultaneous Sampling configuration. Figure 28-12 shows the ADC module operation sequence.

**Note:** On ADC Interrupt, the ADC internal logic is initialized to restart the conversion sequence from the beginning.

Example 28-3: Code Sequence to Set Up ADC for Alternate Input Selection Mode

```
AD1CON1bits.AD12B = 0; // Select 10-bit mode
AD1CON2bits.CHPS = 3; // Select 4-channel mode
AD1CON1bits.SIMSAM = 1; // Enable Simultaneous Sampling
AD1CON2bits.ALTS = 1; // Enable Alternate Input Selection
AD1CON2bits.SMPI = 1; // Select 8 conversion between interrupt
AD1CON1bits.ASAM = 1; // Enable Automatic Sampling
AD1CON1bits.SSRC = 2; // Timer3 generates SOC trigger

// Initialize MUXA Input Selection
AD1CHS0bits.CHOSA = 6; // Select AN6 for CH0 +ve input
AD1CHS0bits.CH0NA = 0; // Select VREF- for CH0 -ve input
AD1CHS123bits.CH123SA = 0; // Select CH1 +ve = AN0, CH2 +ve = AN1, CH3 +ve = AN2
AD1CHS123bits.CH124NA = 0; // Select VREF- for CH1/CH2/CH3 -ve inputs

// Initialize MUXB Input Selection
AD1CHS0bits.CHOSB = 7; // Select AN7 for CH0 +ve input
AD1CHS0bits.CH0NB = 0; // Select VREF- for CH0 -ve input

AD1CHS123bits.CH123SB = 1; // Select CH1 +ve = AN3, CH2 +ve = AN4, CH3 +ve = AN5
```

**Figure 28-12: Alternate Input Selection in 4-Channel Simultaneous Sampling Configuration**

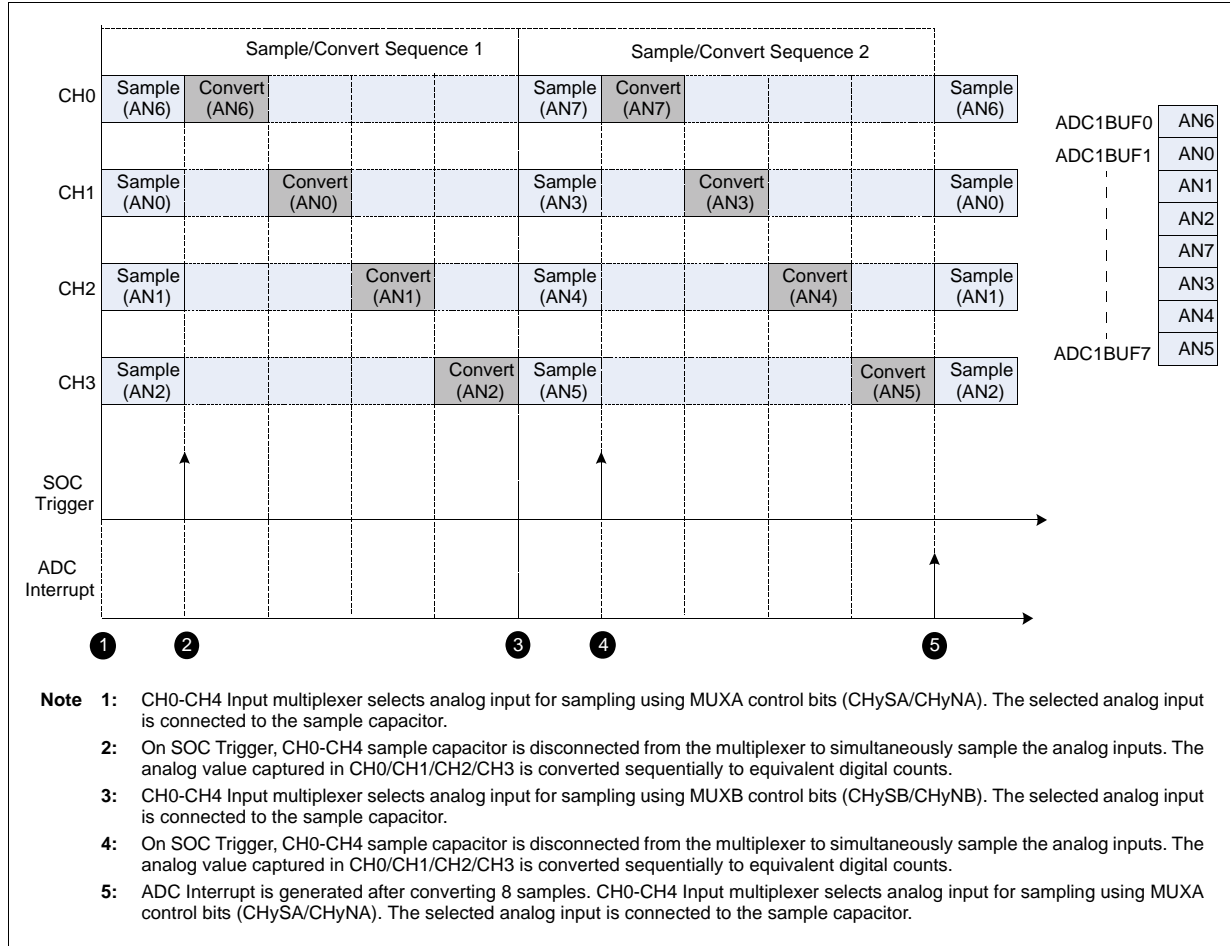

Example 28-4 shows the code sequence to set up the ADC module for Alternate Input Selection mode in a 2-channel sequential sampling configuration.

**Example 28-4: Code Sequence to Set Up ADC for Alternate Input Selection**

```

AD1CON1bits.ADL2B=0;    // Select 10-bit mode
AD1CON2bits.CHPS=1;    // Select 2-channel mode
AD1CON2bits.SMPI = 3;  // Select 4 conversion between interrupt
AD1CON1bits.ASAM = 1;  // Enable Automatic Sampling
AD1CON2bits.ALTS = 1;  // Enable Alternate Input Selection
AD1CON1bits.SIMSAM = 0; // Enable Sequential Sampling
AD1CON1bits.SSRC = 2;  // Timer3 generates SOC trigger

// Initialize MUXA Input Selection
AD1CHS0bits.CHOSA = 6; // Select AN6 for CH0 +ve input
AD1CHS0bits.CHONA = 0; // Select VREF- for CH0 -ve input

AD1CHS123bits.CH123SA=0;// Select AN0 for CH1 +ve input
AD1CHS123bits.CH124NA=0;// Select Vref- for CH1 -ve inputs

// Initialize MUXB Input Selection
AD1CHS0bits.CHOSB = 7; // Select AN7 for CH0 +ve input
AD1CHS0bits.CH0NB = 0; // Select VREF- for CH0 -ve input

AD1CHS123bits.CH123SB=1;// Select AN3 for CH1 +ve input
AD1CHS123bits.CH124NB=0;// Select VREF- for CH1-ve inputs
    
```

# Section 28. Analog-to-Digital Converter (ADC) without DMA

Figure 28-13: Alternate Input Selection in 2-Channel Sequential Sampling Configuration

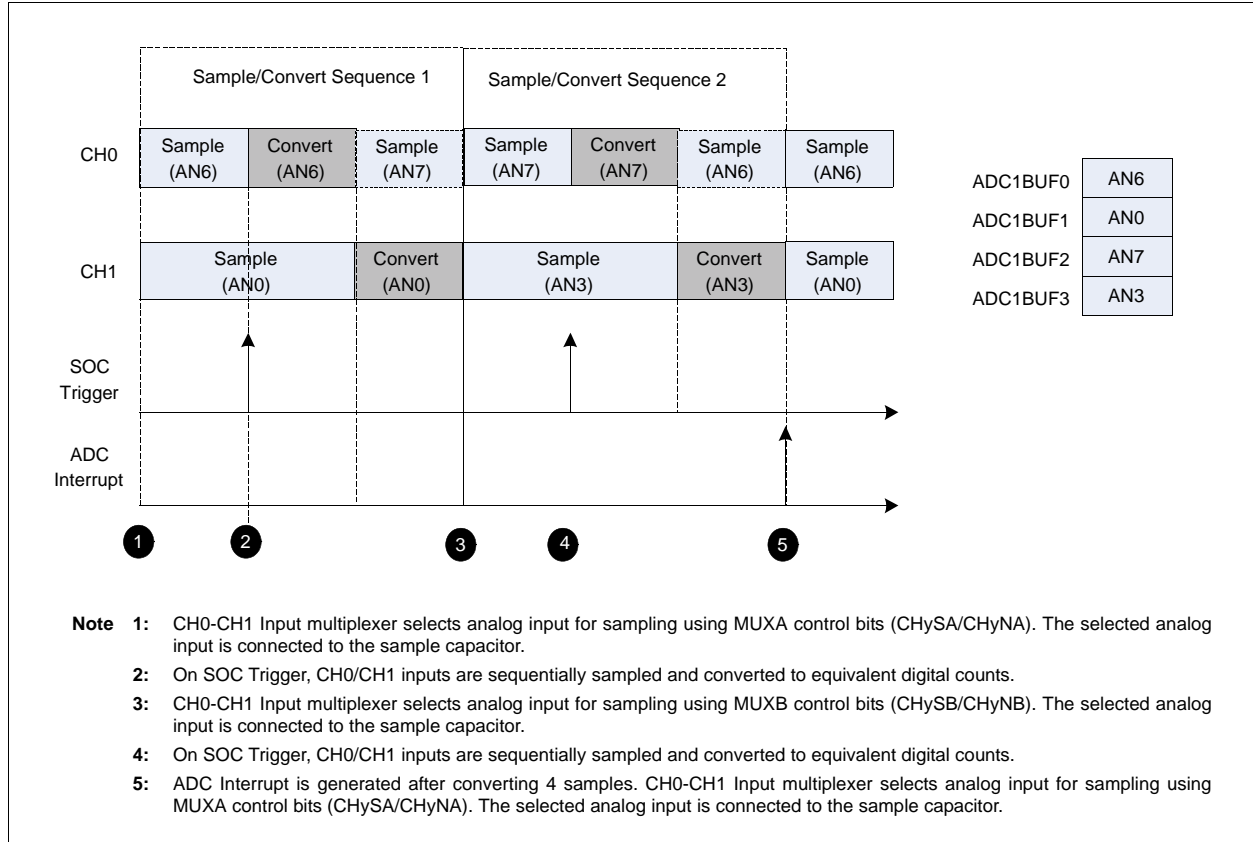

## 28.6.3 Channel Scanning

The ADC module supports the Channel Scan mode using CH0 (Sample/Hold channel '0'). The number of inputs scanned is software selectable. Any subset of the analog inputs from AN0 to AN12 can be selected for conversion. The selected inputs are converted in ascending order. For example, if the input selection includes AN4, AN1, and AN3, the conversion sequence is AN1, AN3, and AN4. The conversion sequence selection is made by programming the Channel Select register (AD1CSSL). A logic '1' in the Channel Select register marks the associated analog input channel for inclusion in the conversion sequence. The Channel Scanning mode is enabled by setting the Channel Scan (CSCNA<10>) bit in the ADC Control register (AD1CON2<10>). In Channel Scan mode, MUXA software control is ignored and the ADC module sequences through the enabled channels.

For every sample/convert sequence, one analog input is scanned. The ADC interrupt must be generated after all selected channels are scanned. If "N" inputs are enabled for channel scan, an interrupt must be generated after "N" sample/convert sequence. Table 28-12 shows the SMPI values to scan "N" analog inputs using CH0 in different ADC configurations.

Table 28-12: Conversions per interrupt in Channel Scan Mode

CHPS<1:0>	SIMSAM	SMPI<3:0> (Decimal)	Conversions/Interrupt	Description
00	x	N-1	N	1-Channel mode
01	0	2N-1	2N	2-Channel Sequential Sampling mode
1x	0	4N-1	4N	4-Channel Sequential Sampling mode
01	1	N-1	2N	2-Channel Simultaneous Sampling mode
1x	1	N-1	4N	4-Channel Simultaneous Sampling mode

Example 28-5 shows the code sequence to scan four analog inputs using CH0. Figure 28-14 shows the ADC operation sequence.

**Note:** On ADC Interrupt, the ADC internal logic is initialized to restart the conversion sequence from the beginning.

### Example 28-5: Code sequence to Scan four Analog Inputs Using CH0

```
AD1CON1bits.AD12B=1;           // Select 12-bit mode, 1-channel mode
AD1CON2bits.SMPI = 3;         // Select 4 conversions between interrupt
AD1CHS0bits.ASAM = 1;        // Enable Automatic Sampling
AD1CON2bits.CSCNA = 1;       // Enable Channel Scanning

// Initialize Channel Scan Selection
AD1CSSLbits.CSS2=1;          // Enable AN2 for scan
AD1CSSLbits.CSS3=1;          // Enable AN3 for scan
AD1CSSLbits.CSS5=1;          // Enable AN5 for scan
AD1CSSLbits.CSS6=1;          // Enable AN6 for scan
```

**Figure 28-14: Scan Four Analog Inputs Using CH0**

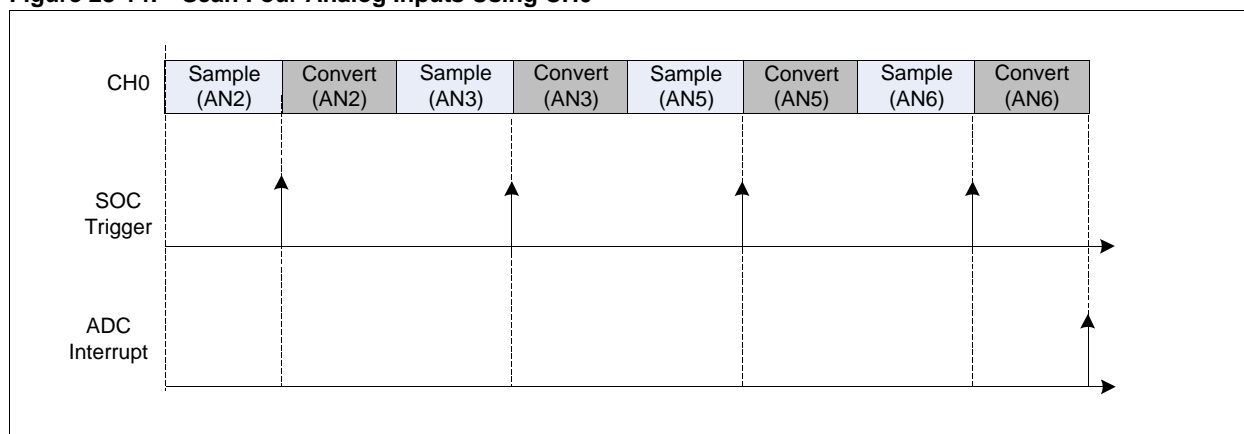

Example 28-6 shows the code sequence to scan two analog inputs using CH0 in a 2-channel alternate input selection configuration. Figure 28-15 shows the ADC operation sequence.

# Section 28. Analog-to-Digital Converter (ADC) without DMA

**Example 28-6: Code sequence for Channel Scan with alternate input selection**

```

AD1CON1bits.AD12B = 0;      // Select 10-bit mode
AD1CON2bits.CHPS = 1;      // Select 2-channel mode
AD1CON1bits.SIMSAM = 0;    // Enable Sequential Sampling
AD1CON2bits.ALTS = 1;     // Enable Alternate Input Selection
AD1CON2bits.CSCNA = 1;    // Enable Channel Scanning
AD1CON2bits.SMPI = 7;     // Select 8 conversion between interrupt
AD1CON1bits.ASAM = 1;     // Enable Automatic Sampling

// Initialize Channel Scan Selection
AD1CSSLbits.CSS2 = 1;     // Enable AN2 for scan
AD1CSSLbits.CSS3 = 1;     // Enable AN3 for scan

// Initialize MUXA Input Selection
AD1CHS123bits.CH123SA = 0; // Select AN0 for CH1 +ve input
AD1CHS123bits.CH124NA = 0; // Select Vref- for CH1 -ve inputs

// Initialize MUXB Input Selection
AD1CHS0bits.CH0SB = 8;    // Select AN8 for CH0 +ve input
AD1CHS0bits.CH0NB = 0;    // Select VREF- for CH0 -ve inputs

AD1CHS123bits.CH123SB = 0; // Select AN4 for CH1 +ve input
AD1CHS123bits.CH124NB = 0; // Select VREF- for CH1 -ve inputs
    
```

**Figure 28-15: Channel Scan with Alternate Input Selection**

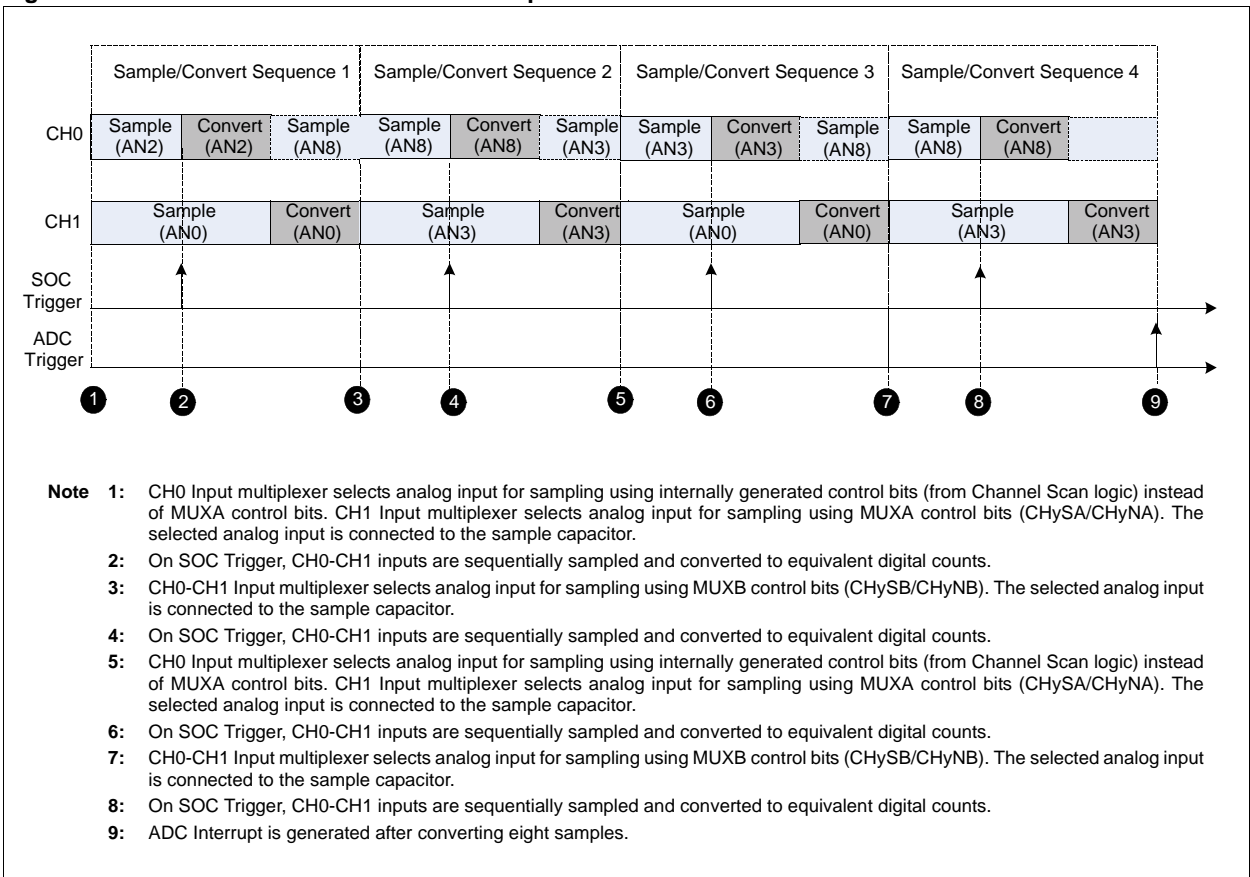

## 28.7 OPERATION DURING SLEEP AND IDLE MODES

Sleep and Idle modes are useful for minimizing conversion noise because the digital activity of the CPU, buses, and other peripherals is minimized.

### 28.7.1 CPU Sleep Mode without RC Analog-to-Digital Clock

When the device enters Sleep mode, all clock sources to the ADC module are shut down and stay at logic '0'.

If Sleep occurs in the middle of a conversion, the conversion is aborted unless the ADC is clocked from its internal RC clock generator. The converter does not resume a partially completed conversion on exiting from Sleep mode.

Register contents are not affected by the device entering or leaving Sleep mode.

### 28.7.2 CPU Sleep Mode with RC Analog-to-Digital Clock

The ADC module can operate during Sleep mode if the analog-to-digital clock source is set to the internal analog-to-digital RC oscillator ( $ADRC = 1$ ). This eliminates digital switching noise from the conversion. When the conversion is completed, the DONE bit is set and the result is loaded into the ADC Result buffer, ADCBUF.

If enabled, the ADC interrupt wakes up the device from Sleep, and the following occurs:

- If the assigned priority for the interrupt is less than, or equal, to the current CPU priority, the device wakes up and continues code execution from the instruction following the `PWRSVAV` instruction that initiated Sleep mode
- If the assigned priority level for the interrupt source is greater than the current CPU priority, the device wakes up and the CPU exception process begins. Code execution continues from the first instruction of the ADC ISR

The user application should select a conversion trigger source that ensures the analog-to-digital conversion takes place in Sleep mode. The automatic conversion trigger option can be used for sampling and conversion in Sleep ( $SSRC<2:0> = 111$ ). To use the automatic conversion option, the ADON bit should be set in the instruction before the `PWRSVAV` instruction.

<b>Note:</b> For the ADC module to operate in Sleep, the ADC clock source must be set to RC ( $ADRC = 1$ ).
---

### 28.7.3 ADC Operation During CPU Idle Mode

When the device enters Idle mode, the system clock sources remain functional and the CPU stops executing code. The ADC Stop-in Idle ( $ADSIDL<13>$ ) bit selection in the ADC Control register ( $AD1CON1<13>$ ) determines whether the module stops in Idle mode or continues to operate in Idle mode.

If  $ICSIDL = 0$ , the module continues to operate in Idle mode, providing full functionality.

If  $ICSIDL = 1$ , the module stops in Idle mode. The module performs the same functions when stopped in Idle mode as for Sleep mode (refer to **28.7.1 “CPU Sleep Mode without RC Analog-to-Digital Clock”** and **28.7.2 “CPU Sleep Mode with RC Analog-to-Digital Clock”**).

# Section 28. Analog-to-Digital Converter (ADC) without DMA

## 28.8 ANALOG-TO-DIGITAL SAMPLING REQUIREMENTS

Figure 28-16 and Figure 28-17 show the analog input model of the 10-bit and 12-bit ADC modes. The total sampling time for the analog-to-digital conversion is a function of the internal amplifier settling time and the holding capacitor charge time.

For the ADC module to meet its specified accuracy, the charge holding capacitor (CHOLD) must be allowed to fully charge to the voltage level on the analog input pin. The analog output source impedance ( $R_s$ ), the interconnect impedance ( $R_{IC}$ ), and the internal sampling switch ( $R_{SS}$ ) impedance combine to directly affect the time required to charge the capacitor CHOLD. The combined impedance must, therefore, be small enough to fully charge the holding capacitor within the chosen sample time. To minimize the effects of pin leakage currents on the accuracy of the ADC module, the maximum recommended source impedance,  $R_s$ , is  $200\Omega$ . After the analog input channel is selected, this sampling function must be completed prior to starting the conversion. The internal holding capacitor is in a discharged state prior to each sample operation.

A minimum time period should be allowed between conversions for the sample time. For more details about the minimum sampling time for a device, refer to the “Electrical Specifications” section in the device data sheet.

**Figure 28-16: Analog Input Model (10-bit Mode)**

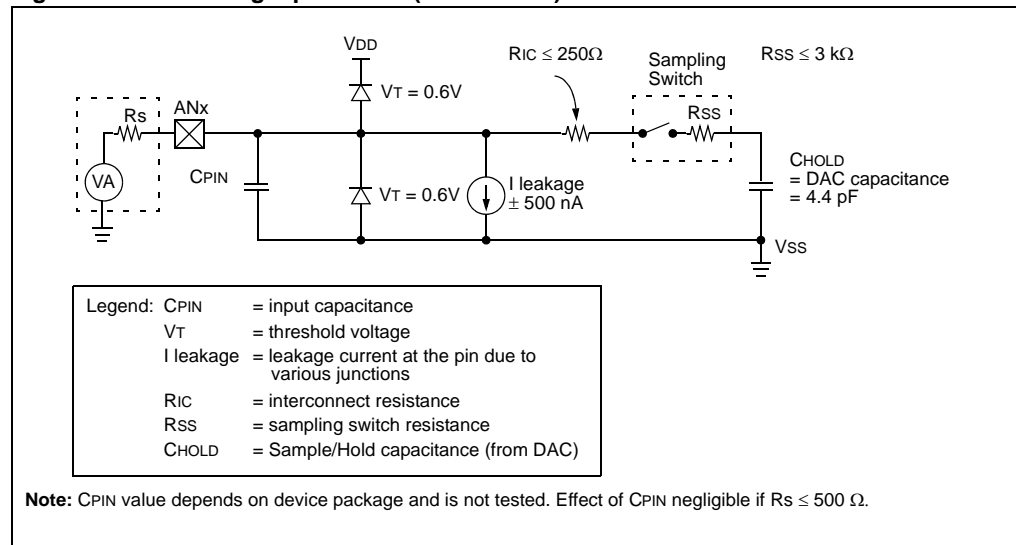

**Figure 28-17: Analog Input Model (12-bit Mode)**

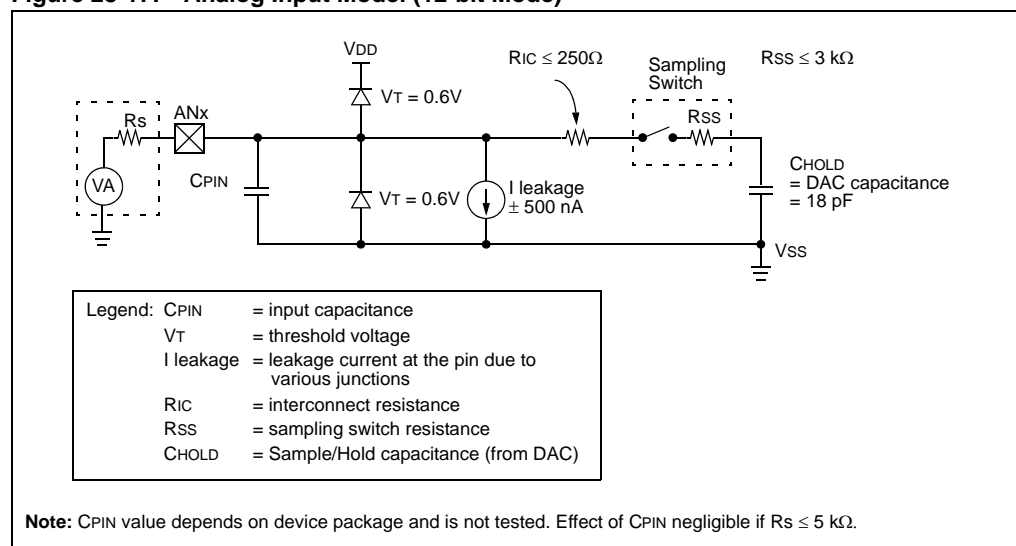

## 28.8.1 Connection Considerations

Since the analog inputs employ ESD protection, they have diodes to  $V_{DD}$  and  $V_{SS}$ . As a result, the analog input must be between  $V_{DD}$  and  $V_{SS}$ . If the input voltage exceeds this range by greater than 0.3 V in either direction, one of the diodes becomes forward-biased, and it damage the device if the input current specification is exceeded.

An external RC filter is sometimes added for anti-aliasing of the input signal. The R component should be selected to ensure that the sampling time requirements are satisfied. Any external components connected (via high-impedance) to an analog input pin (capacitor, Zener diode, etc.) should have very little leakage current at the pin.



# Section 28. Analog-to-Digital Converter (ADC) without DMA

## 28.9 TRANSFER FUNCTION

### 28.9.1 10-bit Mode

Figure 28-18 shows the ideal transfer function of the ADC module. The difference of the input voltages, ( $V_{INH} - V_{INL}$ ), is compared to the reference, ( $V_{REFH} - V_{REFL}$ ).

- The first code transition (A) occurs when the input voltage is  $(V_{REFH} - V_{REFL}/2048)$  or 0.5 LSb
- The 00 0000 0001 code is centered at  $(V_{REFH} - V_{REFL}/1024)$  or 1.0 LSb (B)
- The 10 0000 0000 code is centered at  $(512 \cdot (V_{REFH} - V_{REFL})/1024)$  (C)
- An input voltage less than  $(1 \cdot (V_{REFH} - V_{REFL})/2048)$  converts as 00 0000 0000 (D)
- An input greater than  $(2045 \cdot (V_{REFH} - V_{REFL})/2048)$  converts as 11 1111 1111 (E)

Figure 28-18: ADC Module Transfer Function (10-bit Mode)

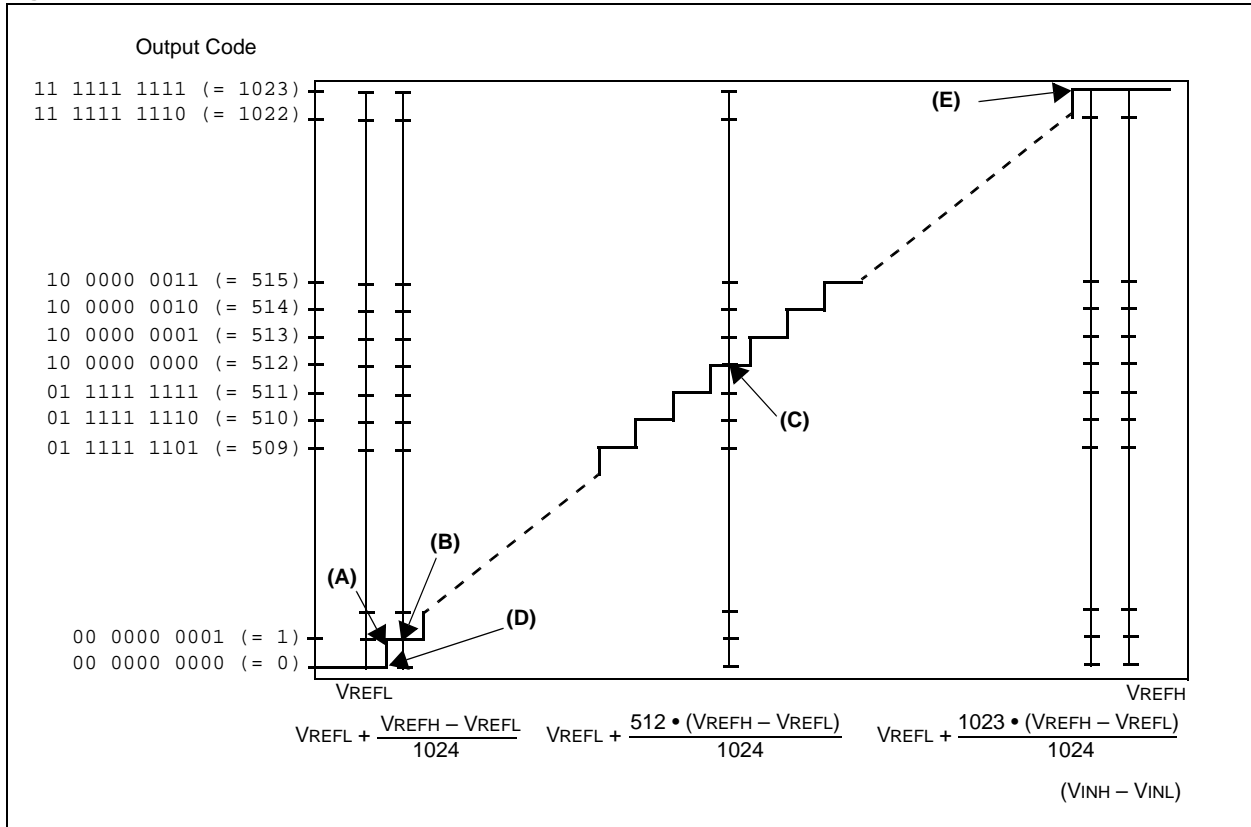

## 28.9.2 Transfer Function (12-bit Mode)

Figure 28-18 shows the ideal transfer function of the ADC. The difference of the input voltages ( $V_{INH} - V_{INL}$ ) is compared to the reference ( $V_{REFH} - V_{REFL}$ ).

- The first code transition (A) occurs when the input voltage is  $(V_{REFH} - V_{REFL}/8192)$  or 0.5 LSb
- The 00 0000 0001 code is centered at  $(V_{REFH} - V_{REFL}/4096)$  or 1.0 LSb (B)
- The 10 0000 0000 code is centered at  $(2048 \cdot (V_{REFH} - V_{REFL})/4096)$  (C)
- An input voltage less than  $(1 \cdot (V_{REFH} - V_{REFL})/8192)$  converts as 00 0000 0000 (D)
- An input greater than  $(8192 \cdot (V_{REFH} - V_{REFL})/8192)$  converts as 11 1111 1111 (E)

Figure 28-19: Analog-to-Digital Transfer Function (12-bit Mode)

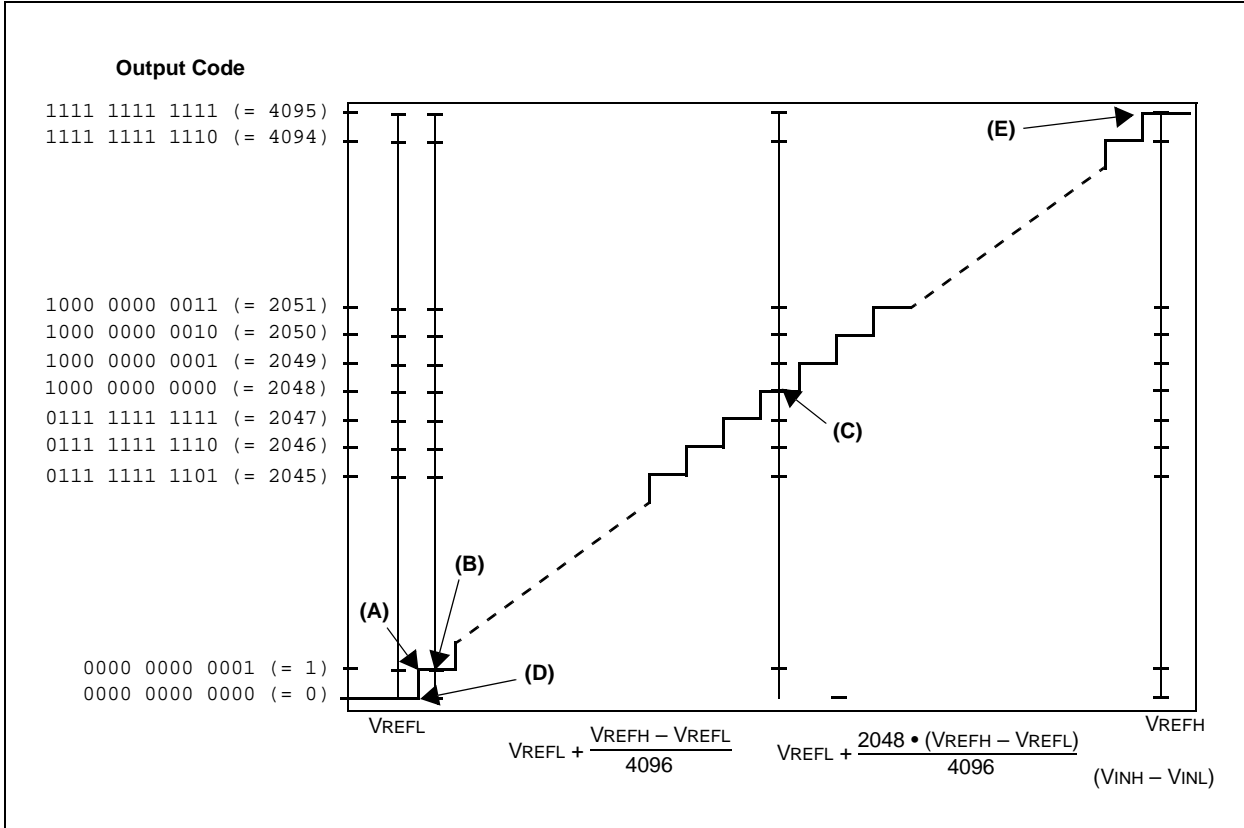

## 28.10 SPECIAL FUNCTION REGISTERS

The following table lists the special function registers, including their addresses and formats. All unimplemented registers and/or bits within a register are read as zeros.

**TABLE 28-4: ADC REGISTER MAP**

File Name	Addr	Bit 15	Bit 14	Bit 13	Bit 12	Bit 11	Bit 10	Bit 9	Bit 8	Bit 7	Bit 6	Bit 5	Bit 4	Bit 3	Bit 2	Bit 1	Bit 0	All Resets	
ADC1BUF0	0300	ADC Data Buffer 0																xxxx	
ADC1BUF1	0302	ADC Data Buffer 1																xxxx	
ADC1BUF2	0304	ADC Data Buffer 2																xxxx	
ADC1BUF3	0306	ADC Data Buffer 3																xxxx	
ADC1BUF4	0308	ADC Data Buffer 4																xxxx	
ADC1BUF5	030A	ADC Data Buffer 5																xxxx	
ADC1BUF6	030C	ADC Data Buffer 6																xxxx	
ADC1BUF7	030E	ADC Data Buffer 7																xxxx	
ADC1BUF8	0310	ADC Data Buffer 8																xxxx	
ADC1BUF9	0312	ADC Data Buffer 9																xxxx	
ADC1BUFA	0314	ADC Data Buffer 10																xxxx	
ADC1BUFB	0316	ADC Data Buffer 11																xxxx	
ADC1BUFC	0318	ADC Data Buffer 12																xxxx	
ADC1BUFD	031A	ADC Data Buffer 13																xxxx	
ADC1BUFE	031C	ADC Data Buffer 14																xxxx	
ADC1BUFF	031E	ADC Data Buffer 15																xxxx	
AD1CON1	0320	ADON	—	ADSIDL	—	—	AD12B	FORM<1:0>		SSRC<2:0>			—	SIMSAM	ASAM	SAMP	DONE	0000	
AD1CON2	0322	VCFG<2:0>			—	—	CSCNA	CHPS<1:0>		BUFS	—	SMPI<3:0>				BUFM	ALTS	0000	
AD1CON3	0324	ADRC	—	—	SAMC<4:0>				ADCS<7:0>							0000			
AD1CHS123	0326	—	—	—	—	—	CH123NB<1:0>		CH123SB	—	—	—	—	—	CH123NA<1:0>		CH123SA	0000	
AD1CHS0	0328	CH0NB	—	—	CH0SB<4:0>				CH0NA	—	—	CH0SA<4:0>							0000
AD1PCFGL	032C	—	—	—	PCFG12	PCFG11	PCFG10	PCFG9	PCFG8	PCFG7	PCFG6	PCFG5	PCFG4	PCFG3	PCFG2	PCFG1	PCFG0	0000	
AD1CSSL	0330	—	—	—	CSS12	CSS11	CSS10	CSS9	CSS8	CSS7	CSS6	CSS5	CSS4	CSS3	CSS2	CSS1	CSS0	0000	

**Legend:** x = unknown value on Reset, — = unimplemented, read as '0'. Reset values are shown in hexadecimal.

## 28.11 DESIGN TIPS

**Question 1:** *How can I optimize the system performance of the ADC module?*

**Answer:** Here are three suggestions for optimizing performance:

- a) Make sure you are meeting all of the timing specifications. If you are turning the ADC module off and on, there is a minimum delay you must wait before taking a sample. If you are changing input channels, there is a minimum delay you must wait for as well. Also, there is TAD, which is the time selected for each bit conversion. TAD is selected in the ADC Control register (AD1CON3) and should be within a range as specified in the "Electrical Characteristics" section of the device data sheet. If TAD is too short, the result may not be fully converted before the conversion is terminated. If TAD is too long, the voltage on the sampling capacitor can decay before the conversion is complete. These timing specifications are provided in the "Electrical Specifications" section of the device data sheet.
- b) Often the source impedance of the analog signal is high (greater than 10 k $\Omega$ ), so the current drawn from the source to charge the sample capacitor can affect accuracy. If the input signal does not change too quickly, put a 0.1  $\mu$ F capacitor on the analog input. This capacitor charges to the analog voltage being sampled and supplies the instantaneous current needed to charge the 4.4 pF internal holding capacitor.
- c) Put the device into Sleep mode before the start of the analog-to-digital conversion. The RC clock source selection is required for conversions in Sleep mode. This technique increases accuracy because digital noise from the CPU and other peripherals is minimized.

**Question 2:** *Do you know of a good reference on Analog-to-Digital conversion?*

**Answer:** A good reference for understanding Analog-to-Digital conversion is the "Analog-Digital Conversion Handbook", Third edition, published by Prentice Hall (ISBN 0-13-03-2848-0).

**Question 3:** *My combination of channels/sample and samples/interrupt is greater than the size of the buffer. What happens to the buffer in this instance?*

**Answer:** The buffer contains unknown results. This configuration is not recommended.

# Section 28. Analog-to-Digital Converter (ADC) without DMA

---

## 28.12 RELATED APPLICATION NOTES

This section lists application notes that are related to this section of the manual. These application notes may not be written specifically for the dsPIC33F device family, but the concepts are pertinent and could be used with modification and possible limitations. The current application notes related to the Analog-to-Digital Converter (ADC) without DMA module are:

Title	Application Note #
Using the Analog-to-Digital (A/D) Converter	AN546
4-Channel Digital Voltmeter with Display and Keyboard	AN557
Understanding A/D Converter Performance Specifications	AN693
Using the dsPIC30F for Sensorless BLDC Control	AN901
Using the dsPIC30F for Vector Control of an ACIM	AN908
Sensored BLDC Motor Control Using the dsPIC30F2010	AN957
An Introduction to AC Induction Motor Control Using the dsPIC30F MCU	AN984

**Note:** For additional application notes and code examples for the dsPIC33F device family, visit the Microchip website ([www.microchip.com](http://www.microchip.com)).

## 28.13 REVISION HISTORY

### Revision A (June 2007)

This is the initial released version of this document.