

Request For Quotation

Order the parts you need from our real-time inventory database. Simply complete a request for quotation form with your part information and a sales representative will respond to you with price and availability.

[Request For Quotation](#)

Your free datasheet starts on the next page.

More datasheets and data books are available from our homepage: <http://www.datasheetarchive.com>

TMS4116

16,384-BIT DYNAMIC RANDOM-ACCESS MEMORY

OCTOBER 1977—REVISED NOVEMBER 1985

- 16,384 X 1 Organization
- 10% Tolerance on All Supplies
- All Inputs Including Clocks TTL Compatible
- Unlatched Three-State Fully TTL-Compatible Output
- Performance Ranges:

	ACCESS TIME ROW ADDRESS (MAX)	ACCESS TIME COLUMN ADDRESS (MAX)	READ OR WRITE CYCLE (MIN)	READ- MODIFY- WRITE [†] CYCLE (MIN)
TMS4116-15	150 ns	100 ns	375 ns	375 ns
TMS4116-20	200 ns	135 ns	375 ns	375 ns
TMS4116-25	250 ns	165 ns	410 ns	515 ns

- Page-Mode Operation for Faster Access Time
- Common I/O Capability with Early Write Feature
- Low-Power Dissipation
 - Operating . . . 462 mW (Max)
 - Standby . . . 20 mW (Max)
- 1-T Cell Design, N-Channel Silicon-Gate Technology
- 16-Pin 300-Mil (7,62-mm) Package Configuration

N PACKAGE
(TOP VIEW)

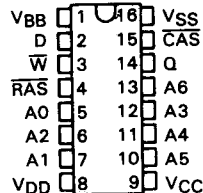

PIN NOMENCLATURE	
A0-A6	Addresses
CAS	Column-Address Strobe
D	Data Input
Q	Data Output
RAS	Row-Address Strobe
VBB	-5-V Power Supply
VCC	5-V Power Supply
VDD	12-V Power Supply
VSS	Ground
W	Write Enable

description

The TMS4116 series is composed of monolithic high-speed dynamic 16,384-bit MOS random-access memories organized as 16,384 one-bit words, and employs single-transistor storage cells and N-channel silicon-gate technology.

All inputs and outputs are compatible with Series 74 TTL circuits including clocks: Row-Address Strobe \overline{RAS} (or \overline{R}) and Column-Address Strobe \overline{CAS} (or \overline{C}). All address lines (A0 through A6) and data in (D) are latched on chip to simplify system design. Data out (Q) is unlatched to allow greater system flexibility.

Typical power dissipation is less than 350 milliwatts active and 6 milliwatts during standby (V_{CC} is not required during standby operation). To retain data, only 10 milliwatts average power is required which includes the power consumed to refresh the contents of the memory.

The TMS4116 series is offered in a 16-pin dual-in-line plastic (N suffix) package and is guaranteed for operation from 0°C to 70°C. The package is designed for insertion in mounting-hole rows on 7,62-mm (300-mil) centers.

operation

address (A0-A6)

Fourteen address bits are required to decode 1 of 16,384 storage cell locations. Seven row-address bits are set up on pins A0 through A6 and latched onto the chip by the row-address strobe (\overline{RAS}). Then the

[†]The term "read-write cycle" is sometimes used as an alternative to "read-modify-write cycle."

PRODUCTION DATA documents contain information current as of publication date. Products conform to specifications per the terms of Texas Instruments standard warranty. Production processing does not necessarily include testing of all parameters.



POST OFFICE BOX 1443 • HOUSTON, TEXAS 77001

Copyright © 1985, Texas Instruments Incorporated

seven column-address bits are set up on pins A0 through A6 and latched onto the chip by the column-address strobe ($\overline{\text{CAS}}$). All addresses must be stable on or before the falling edges of $\overline{\text{RAS}}$ and $\overline{\text{CAS}}$. $\overline{\text{RAS}}$ is similar to a chip enable in that it activates the sense amplifiers as well as the row decoder. $\overline{\text{CAS}}$ is used as a chip select activating the column decoder and the input and output buffers.

write enable ($\overline{\text{W}}$)

The read or write mode is selected through the write-enable ($\overline{\text{W}}$) input. A logic high on the $\overline{\text{W}}$ input selects the read mode and a logic low selects the write mode. The write-enable terminal can be driven from standard TTL circuits without a pull-up resistor. The data input is disabled when the read mode is selected. When $\overline{\text{W}}$ goes low prior to $\overline{\text{CAS}}$, data out will remain in the high-impedance state for the entire cycle permitting common I/O operation.

data in ($\overline{\text{D}}$)

Data is written during a write or read-modify-write cycle. Depending on the mode of operation, the falling edge of $\overline{\text{CAS}}$ or $\overline{\text{W}}$ strobes data into the on-chip data latch. This latch can be driven from standard TTL circuits without a pull-up resistor. In an early write cycle, $\overline{\text{W}}$ is brought low prior to $\overline{\text{CAS}}$ and the data is strobed in by $\overline{\text{CAS}}$ with setup and hold times referenced to this signal. In a delayed-write or read-modify-write cycle, $\overline{\text{CAS}}$ will already be low, thus the data will be strobed in by $\overline{\text{W}}$ with setup and hold times referenced to this signal.

data out (Q)

The three-state output buffer provides direct TTL compatibility (no pull-up resistor required) with a fan out of two Series 74 TTL loads. Data out is the same polarity as data in. The output is in the high-impedance (floating) state until $\overline{\text{CAS}}$ is brought low. In a read cycle, the output goes active after the enable time interval $t_{a(C)}$ that begins with the negative transition of $\overline{\text{CAS}}$ as long as $t_{a(R)}$ is satisfied. The output becomes valid after the access time has elapsed and remains valid while $\overline{\text{CAS}}$ is low; $\overline{\text{CAS}}$ going high returns it to a high-impedance state. In an early write cycle, the output is always in the high-impedance state. In a delayed-write or read-modify-write cycle, the output will follow the sequence for the read cycle.

refresh

A refresh operation must be performed at least every two milliseconds to retain data. Since the output buffer is in the high-impedance state unless $\overline{\text{CAS}}$ is applied, the $\overline{\text{RAS}}$ -only refresh sequence avoids any output during refresh. Strobing each of the 128 row addresses (A0 through A6) with $\overline{\text{RAS}}$ causes all bits in each row to be refreshed. $\overline{\text{CAS}}$ remains high (inactive) for this refresh sequence, thus conserving power.

page mode

Page-mode operation allows effectively faster memory access by keeping the same row address and strobing successive column addresses onto the chip. Thus, the time required to setup and strobe sequential row addresses on the same page is eliminated. To extend beyond the 128 column locations on a single RAM, the row address and $\overline{\text{RAS}}$ is applied to multiple 16K RAMs; $\overline{\text{CAS}}$ is decoded to select the proper RAM.

power up

V_{BB} must be applied to the device either before or at the same time as the other supplies and removed last. Failure to observe this precaution will cause dissipation in excess of the absolute maximum ratings due to internal forward bias conditions. This also applies to system use, where failure of the V_{BB} supply must immediately shut down the other supplies. After power up, eight $\overline{\text{RAS}}$ cycles must be performed to achieve proper device operation.

logic symbol†

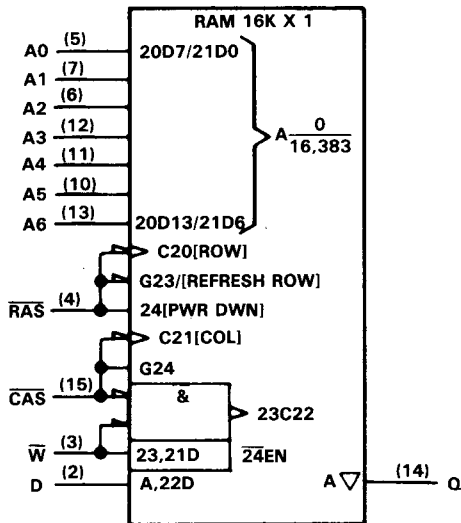

†This symbol is in accordance with ANSI/IEEE Std 91-1984 and IEC Publication 617-12.

functional block diagram

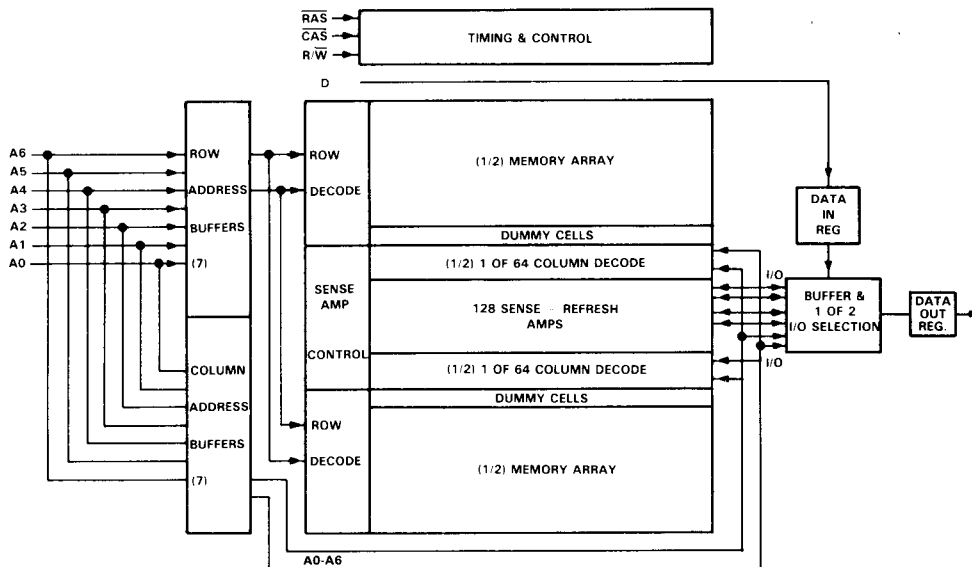

TMS4116
16,384-BIT DYNAMIC RANDOM-ACCESS MEMORY

absolute maximum ratings over operating free-air temperature range (unless otherwise noted)†

Voltage on any pin (see Note 1)	-0.5 V to 20 V
Voltage on VCC, VDD supplies with respect to VSS	-1 V to 15 V
Short circuit output current	50 mA
Power dissipation	1 W
Operating free-air temperature range	0°C to 70°C
Storage temperature range	-65°C to 150°C

† Stresses beyond those listed under "Absolute Maximum Ratings" may cause permanent damage to the device. This is a stress rating only and functional operation of the device at these or any other conditions beyond those indicated in the "Recommended Operating Conditions" section of this specification is not implied. Exposure to absolute-maximum-rated conditions for extended periods may affect device reliability.

NOTE 1: Under absolute maximum ratings, voltage values are with respect to the most-negative supply voltage, V_{BB} (substrate), unless otherwise noted. Throughout the remainder of this data sheet, voltage values are with respect to V_{SS}.

4

Dynamic RAMS

recommended operating conditions

		MIN	NOM	MAX	UNIT	
V _{BB}	Supply voltage	-4.5	-5	-5.5	V	
V _{CC}	Supply voltage	4.5	5	5.5	V	
V _{DD}	Supply voltage	10.8	12	13.2	V	
V _{SS}	Supply voltage	0			V	
V _{IH}	High-level input voltage	All inputs except RAS, CAS, WRITE			V	
		RAS, CAS, WRITE				
V _{IL}	Low-level input voltage (see Note 2)	-1	0	0.8	V	
T _A	Operating free-air temperature	0			70	°C

NOTE 2: The algebraic convention, where the more negative (less positive) limit is designated as maximum, is used in this data sheet for logic voltage only.

electrical characteristics over full ranges of recommended operating conditions (unless otherwise noted)

PARAMETER		TEST CONDITIONS	MIN	TYP [†]	MAX	UNIT
V _{OH}	High-level output voltage	I _{OH} = -5 mA	2.4			V
V _{OL}	Low-level output voltage	I _{OL} = 4.2 mA			0.4	V
I _I	Input current (leakage)	V _I = 0 V to 7 V, All other pins = 0 V except V _{BB} = -5 V			10	μA
I _O	Output current (leakage)	V _O = 0 to 5.5 V, C _{AS} high			± 10	μA
I _{BB1}	Average operating current during read or write cycle	Minimum cycle time		50	200	μA
I _{CC1} [‡]				4 [§]		mA
I _{DD1}				27	35	mA
I _{BB2}	Standby current	After 1 memory cycle R _{AS} and C _{AS} high		10	100	μA
I _{CC2}				± 10		mA
I _{DD2}				0.5	1.5	mA
I _{BB3}	Average refresh current	Minimum cycle time R _{AS} cycling, C _{AS} high		50	200	μA
I _{CC3}				± 10		mA
I _{DD3}				20	27	mA
I _{BB4}	Average page-mode current	Minimum cycle time R _{AS} low, C _{AS} cycling		50	200	μA
I _{CC4} [‡]				4 [§]		mA
I _{DD4}				20	27	mA

† All typical values are at T_A = 25°C and nominal supply voltages.
[‡] V_{CC} is applied only to the output buffer, so I_{CC} depends on output loading.
[§] Output loading two standard TTL loads.

capacitance over recommended supply voltage range and operating free-air temperature range, f = 1 MHz

PARAMETER		TYP [†]	MAX	UNIT
C _{i(A)}	Input capacitance, address inputs	4	5	pF
C _{i(D)}	Input capacitance, data input	4	5	pF
C _{i(RC)}	Input capacitance, strobe inputs	8	10	pF
C _{i(W)}	Input capacitance, write enable input	8	10	pF
C _o	Output capacitance	5	7	pF

switching characteristics over recommended supply voltage range and operating free-air temperature range

PARAMETER	TEST CONDITIONS	ALT. SYMBOL	TMS4116-15		TMS4116-20		TMS4116-25		UNIT
			MIN	MAX	MIN	MAX	MIN	MAX	
t _{a(C)}	Access time from C _{AS}	t _{CAC}	100		135		165		ns
t _{a(R)}	Access time from R _{AS}	t _{RAC}	150		200		250		ns
t _{dis(CH)}	Output disable time after C _{AS} high	t _{OFF}	0	40	0	50	0	60	ns

† All typical values are at T_A = 25°C and nominal supply voltages.

TMS4116
16,384-BIT DYNAMIC RANDOM-ACCESS MEMORY

timing requirements over recommended supply voltage range and operating free-air temperature range

	ALT. SYMBOL	TMS4116-15		TMS4116-20		TMS4116-25		UNIT
		MIN	MAX	MIN	MAX	MIN	MAX	
t _{c(P)} Page-mode cycle time	t _{PC}	170		225		275		ns
t _{c(rd)} Read cycle time	t _{RC}	375		375		410		ns
t _{c(W)} Write cycle time	t _{WC}	375		375		410		ns
t _{c(rdW)} Read-modify-write cycle time	t _{RWC}	375		375		515		ns
t _{w(CH)} Pulse duration, $\overline{\text{CAS}}$ high (precharge time)	t _{CP}	60		80		100		ns
t _{w(CL)} Pulse duration, $\overline{\text{CAS}}$ low	t _{CAS}	100	10,000	135	10,000	165	10,000	ns
t _{w(RH)} Pulse duration, $\overline{\text{RAS}}$ high (precharge time)	t _{RP}	100		120		150		ns
t _{w(RL)} Pulse duration, $\overline{\text{RAS}}$ low	t _{RAS}	150	10,000	200	10,000	250	10,000	ns
t _{w(W)} Write pulse duration	t _{WP}	45		55		75		ns
t _t Transition times (rise and fall) for $\overline{\text{RAS}}$ and CAS	t _T	3	35	3	50	3	50	ns
t _{su(CA)} Column-address setup time	t _{ASC}	-10		-10		-10		ns
t _{su(RA)} Row-address setup time	t _{ASR}	0		0		0		ns
t _{su(D)} Data setup time	t _{DS}	0		0		0		ns
t _{su(rd)} Read-command setup time	t _{RCS}	0		0		0		ns
t _{su(WCH)} Write-command setup time before $\overline{\text{CAS}}$ high	t _{CWL}	60		80		100		ns
t _{su(WRH)} Write-command setup time before $\overline{\text{RAS}}$ high	t _{RWL}	60		80		100		ns
t _{h(CLCA)} Column-address hold time after $\overline{\text{CAS}}$ low	t _{CAH}	45		55		75		ns
t _{h(RA)} Row-address hold time	t _{RAH}	20		25		35		ns
t _{h(RLCA)} Column-address hold time after $\overline{\text{RAS}}$ low	t _{AR}	95		120		160		ns
t _{h(CLD)} Data hold time after $\overline{\text{CAS}}$ low	t _{DHC}	45		55		75		ns
t _{h(RLD)} Data hold time after $\overline{\text{RAS}}$ low	t _{DHR}	95		120		160		ns
t _{h(WLD)} Data hold time after $\overline{\text{W}}$ low	t _{DHW}	45		55		75		ns
t _{h(rd)} Read-command hold time	t _{RCH}	0		0		0		ns
t _{h(CLW)} Write-command hold time after $\overline{\text{CAS}}$ low	t _{WCH}	45		55		75		ns
t _{h(RLW)} Write-command hold time after $\overline{\text{RAS}}$ low	t _{WCR}	95		120		160		ns
t _{RLCH} Delay time, $\overline{\text{RAS}}$ low to $\overline{\text{CAS}}$ high	t _{CSH}	150		200		250		ns
t _{CHRL} Delay time, $\overline{\text{CAS}}$ high to $\overline{\text{RAS}}$ low	t _{CRP}	-20		-20		-20		ns
t _{CLRH} Delay time, $\overline{\text{CAS}}$ low to $\overline{\text{RAS}}$ high	t _{RSH}	100		135		165		ns
t _{CLWL} Delay time, $\overline{\text{CAS}}$ low to $\overline{\text{W}}$ low (read-modify-write-cycle only)	t _{CWD}	70		95		125		ns
t _{RLCL} Delay time, $\overline{\text{RAS}}$ low to $\overline{\text{CAS}}$ low (maximum value specified only to guarantee access time)	t _{RCD}	20	50	25	65	35	85	ns
t _{RLWL} Delay time, $\overline{\text{RAS}}$ low to $\overline{\text{W}}$ low (read-modify-write-cycle only)	t _{RWD}	120		160		200		ns
t _{WLCL} Delay time, $\overline{\text{W}}$ low to $\overline{\text{CAS}}$ low (early write cycle)	t _{WCS}	-20		-20		-20		ns
t _{rf} Refresh time interval	t _{REF}		2		2		2	ms

4

Dynamic RAMS

read cycle timing

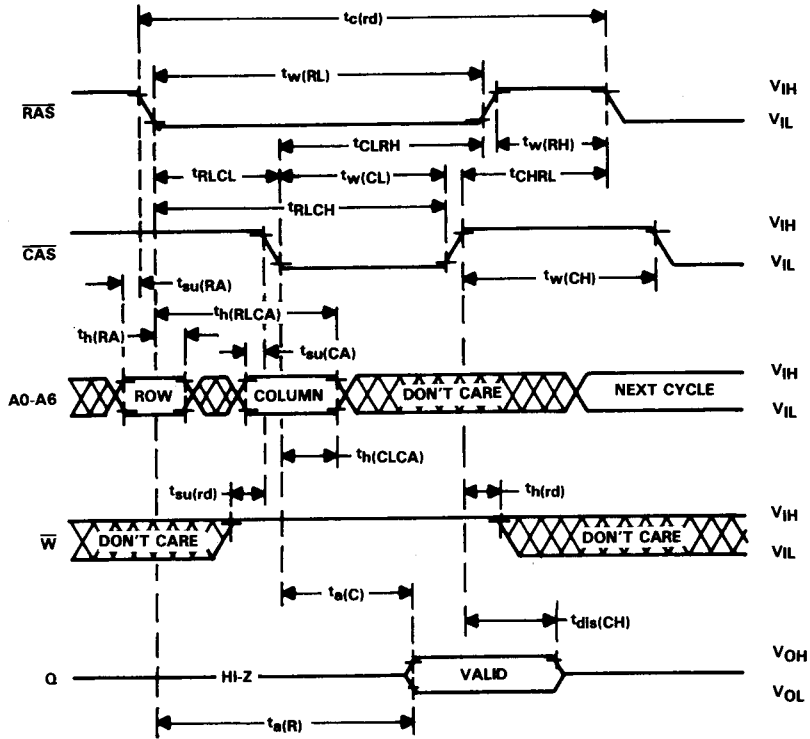

TMS4116
16,384-BIT DYNAMIC RANDOM-ACCESS MEMORY

early write cycle timing

4

Dynamic RAMs

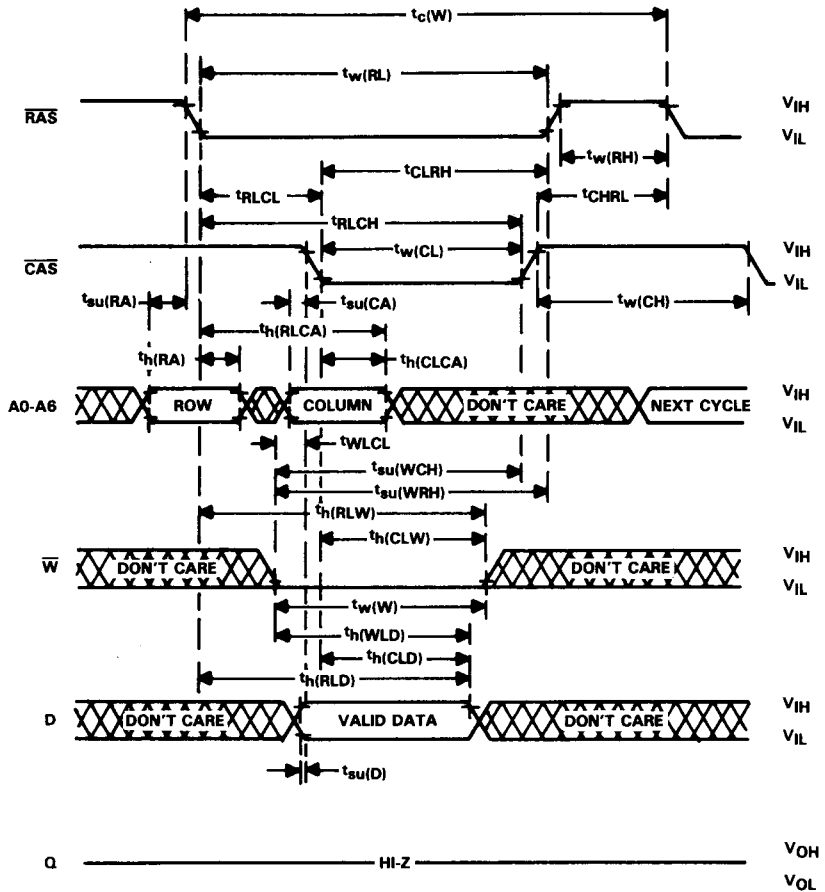

write cycle timing

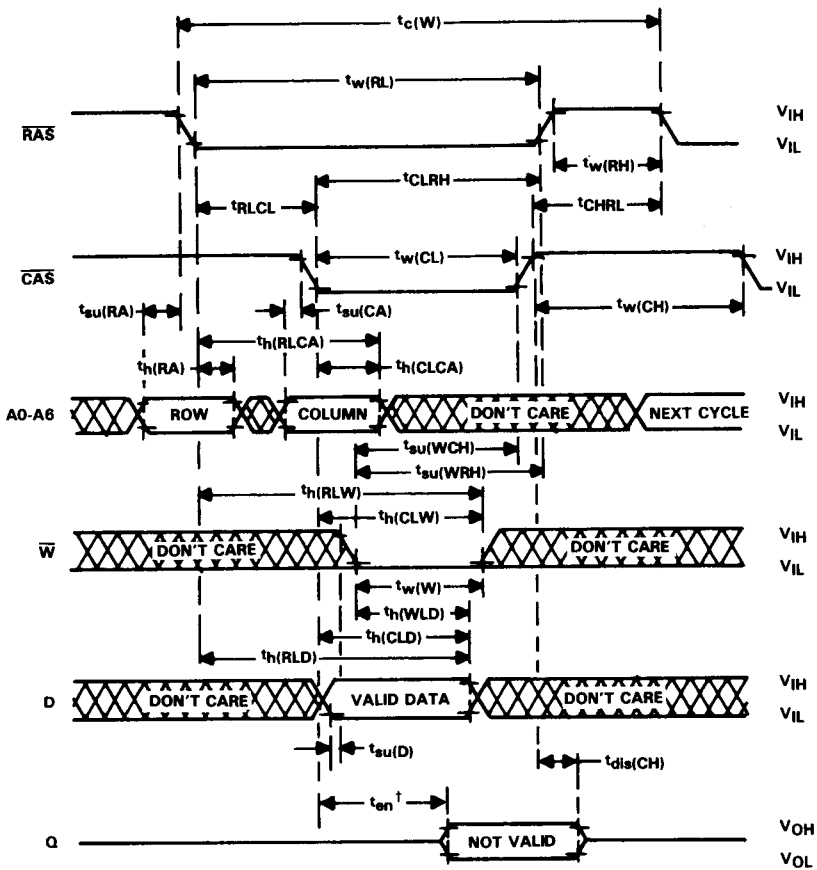

† The enable time (t_{en}) for a write cycle is equal in duration to the access time from \overline{CAS} ($t_{a(C)}$) in a read cycle; but the same active levels at the output are invalid.

TMS4116
16,384-BIT DYNAMIC RANDOM-ACCESS MEMORY

read-write/read-modify-write cycle timing

4
Dynamic RAMS

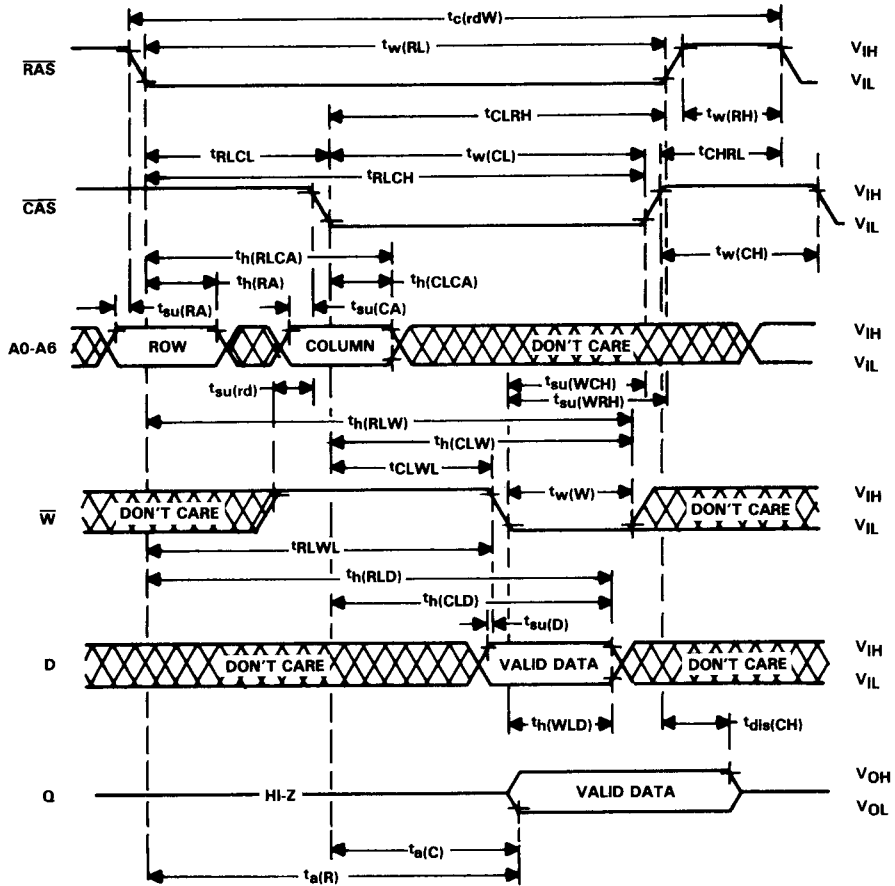

page-mode read cycle timing

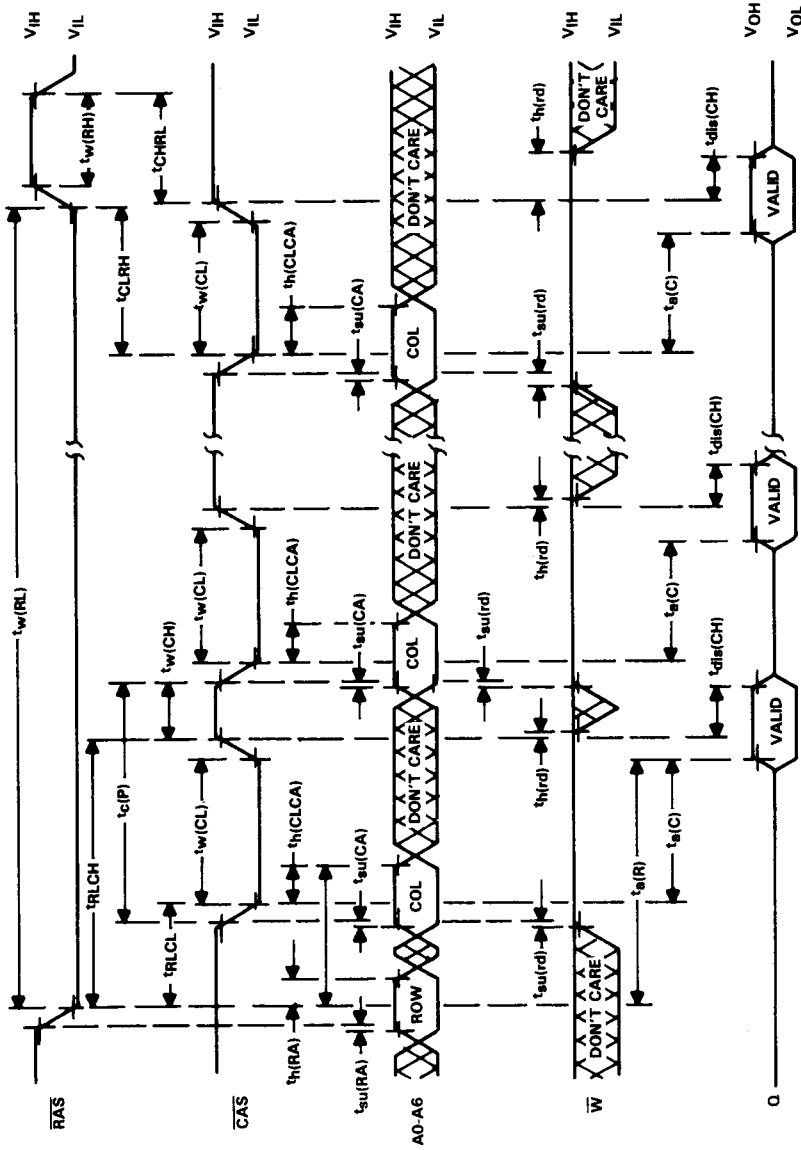

page-mode write cycle timing

4

Dynamic RAMs

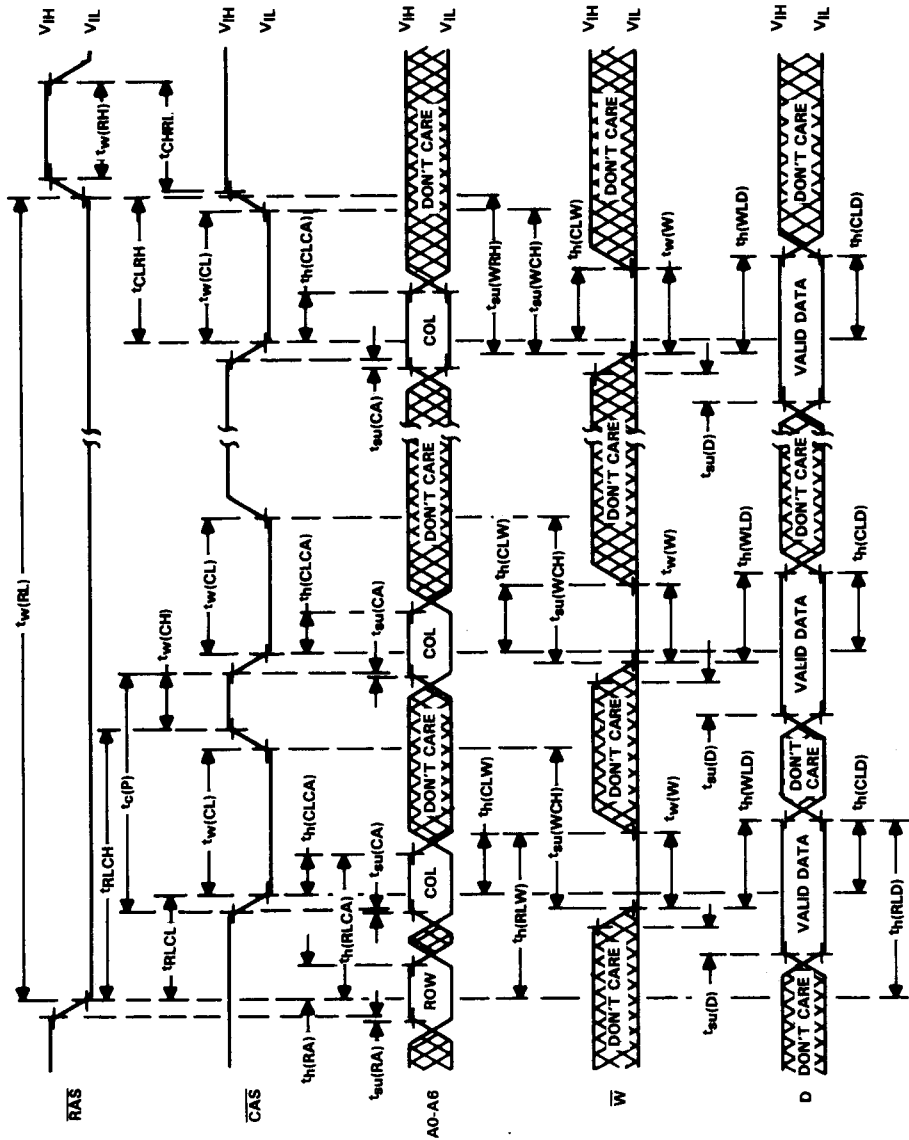

RAS-only refresh timing

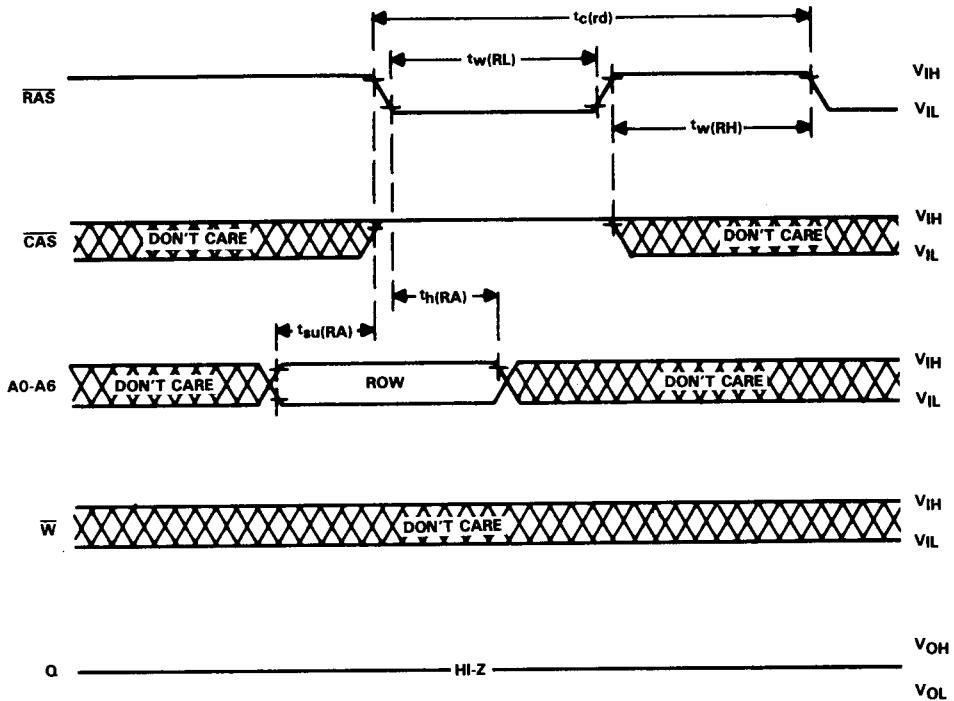

TMS4116
16,384-BIT DYNAMIC RANDOM-ACCESS MEMORY

4

Dynamic RAMs

